

Texas Electric Restructuring & Systems Standards



Rebecca Klein

September 20, 2001

Gas Industry Standards Board

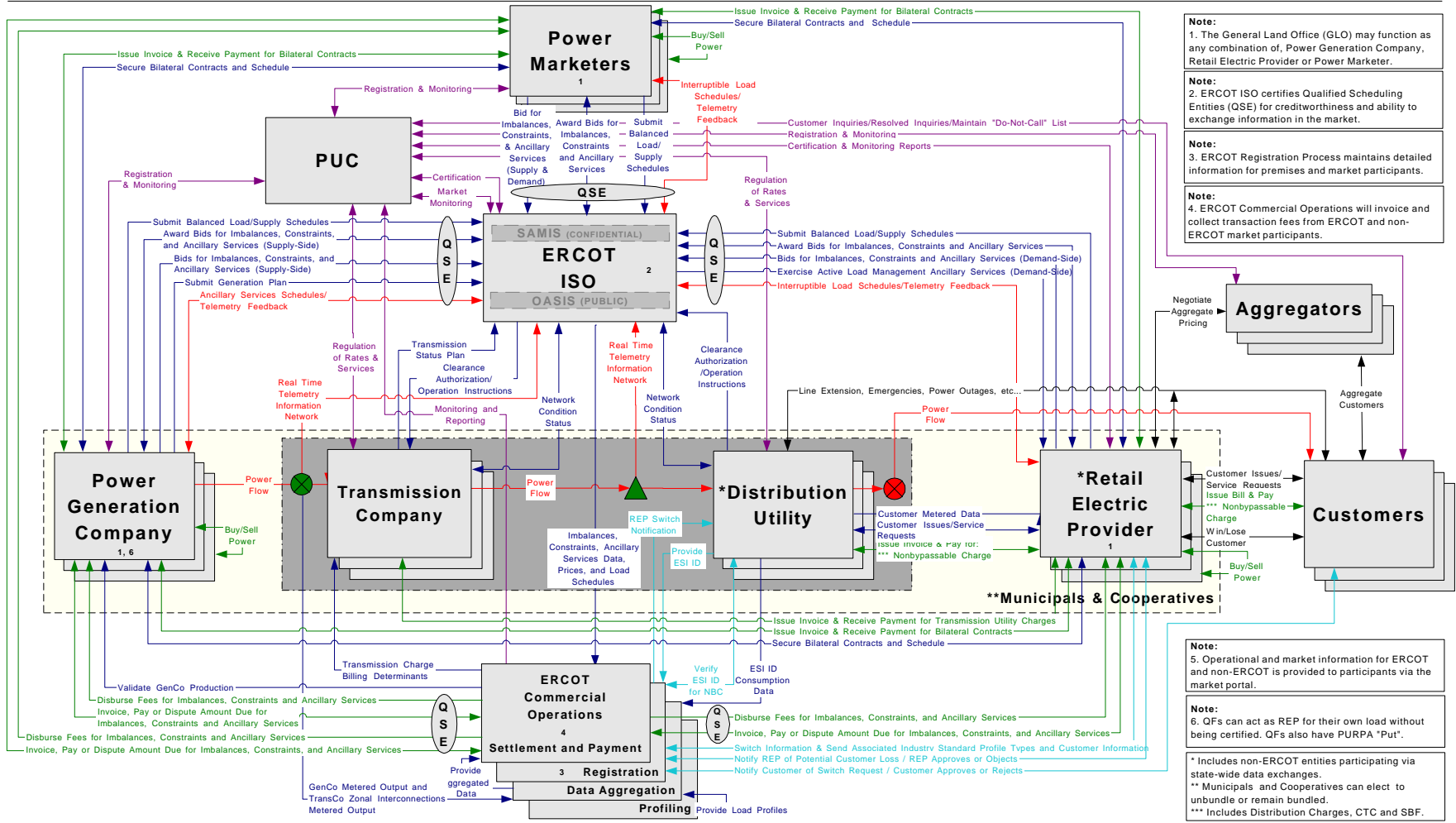

Note:
1. The General Land Office (GLO) may function as any combination of, Power Generation Company, Retail Electric Provider or Power Marketer.

Note:
2. ERCOT ISO certifies Qualified Scheduling Entities (QSE) for creditworthiness and ability to exchange information in the market.

Note:
3. ERCOT Registration Process maintains detailed information for premises and market participants.

Note:
4. ERCOT Commercial Operations will invoice and collect transaction fees from ERCOT and non-ERCOT market participants.

Note:
5. Operational and market information for ERCOT and non-ERCOT is provided to participants via the market portal.

Note:
6. QFs can act as REP for their own load without being certified. QFs also have PURPA "Put".

* Includes non-ERCOT entities participating via state-wide data exchanges.
** Municipals and Cooperatives can elect to unbundle or remain bundled.
*** Includes Distribution Charges, CTC and SBF.

Key:

- Real Time Operations
- Customer Interactions
- ERCOT Data Exchanges
- State-wide Data Exchanges
- Financial Flows
- Regulatory Interactions
- Meter
- Settlement Meter
- Telemetry

Basic Transaction Flow

(Does Not Include Monthly Usage or Drop to Current CR Transactions)

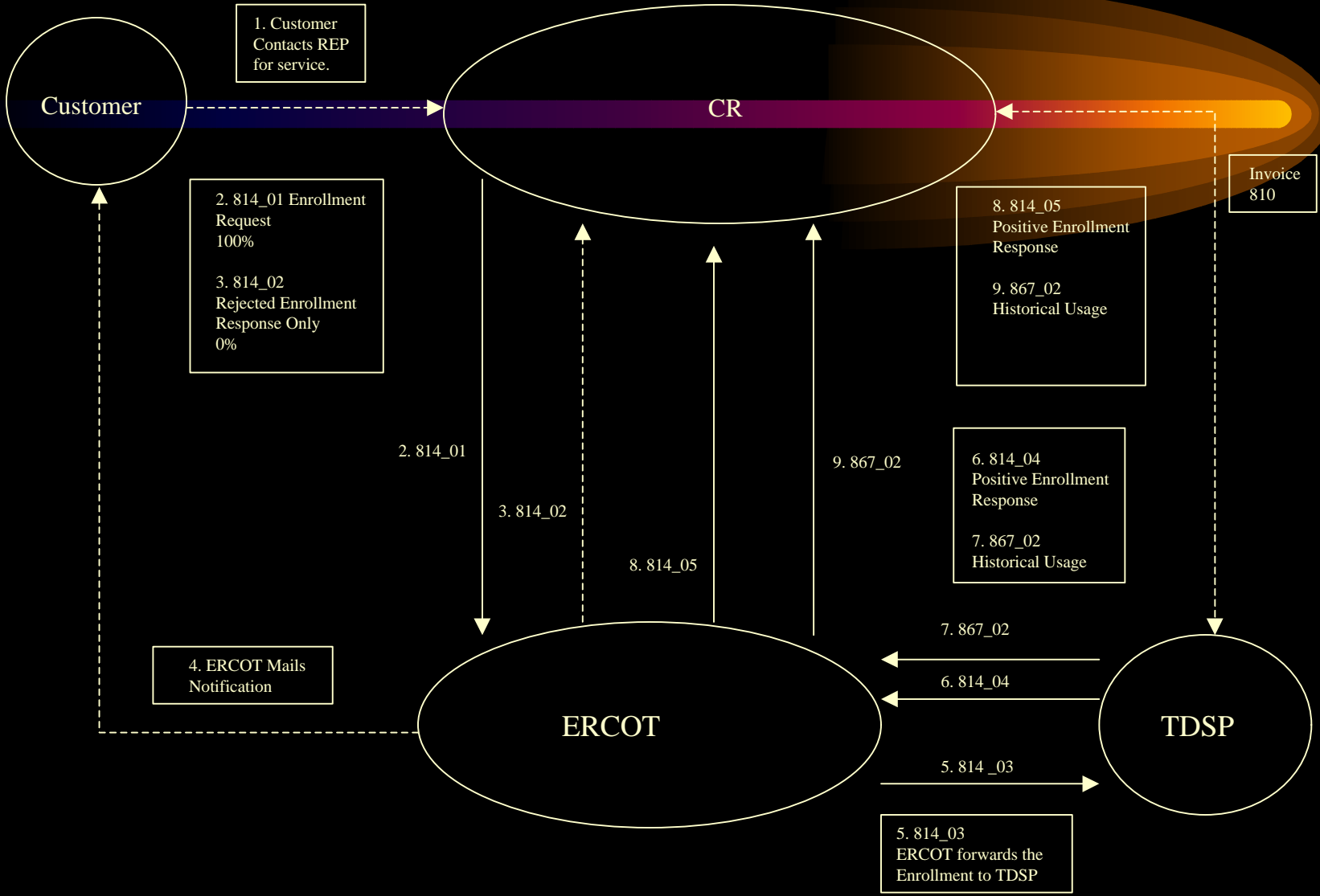

ERCOT

```
graph TD; ERCOT[ERCOT] --- TAC((TAC)); TAC --- RM[Retail Market]; TAC --- PR[Protocol Revisions]; TAC --- RO[Reliability & Ops]; TAC --- WM[Wholesale Market];
```

TAC

Retail
Market

Protocol
Revisions

Reliability &
Ops

Wholesale
Market

TX SET - System Standards

- Data Transport - ANSCI X12
- Data Transport Protocol - GISB
 - Point to Point only; flow to/from ERCOT = ftp
- Non-ERCOT Regions Comply w/ TXSET
- QSEs Comply w/ TXSET for invoices.
Other standards are customized, but uniform

Protocols - Process Standards



- Scope
- Development
- Changes

Flight Testing - System and Process Verification



- Timing
- Who Must Test
- How Long do They Last
- What About new Retailers Entering Market