

**Coordinate Interchange Standards
Reference Document**

Contents:

Introduction 2

Scope of Proposed Standards 3

 Standards Focus on Reliability and Coordinate with NAESB’s Business Practice and Version 0 Standards 3

 The Six Proposed Coordinate Interchange Standards: 4

 Coordination with Version 0 Coordinate Interchange Standards 4

 Interchange Authority Introduced 5

 Standards are Performance-Based 5

 Proposed Standards Limited to Interchange Between Balancing Authorities 5

Identifying the Entities that Perform the Interchange Authority Tasks Today 6

 Who Performs the Interchange Authority Function Today and in the Future? 6

 Number of Interchange Authorities 6

 Relationship to Functional Model 6

Interpreting the Proposed Coordinate Interchange Standards 8

 Terminology 8

 Timing 11

 Dynamic Schedules 13

 Pseudo-Ties 13

 DC Ties 13

 The “Normal” Process of Coordinating Interchange 14

 Interchange Changes for Reliability Reasons 15

 Interchange Changes for Market Reasons 16

Introduction

This document explains the assumptions the Coordinate Interchange Drafting Team used to create the draft Coordinate Interchange Standards. The Drafting Team chose to take an “evolutionary” rather than “revolutionary” approach to the implementation of the Interchange Authority (IA) defined by the Functional Model Version 2. Recent discussions within the industry have indicated that the full implementation of the IA as defined in the Functional Model does not represent the current functioning of the industry – particularly as it relates to electronic tagging and the concepts of “authority.” The Drafting Team felt that a modified version of the IA from that defined in the Functional Model would introduce the IA into the standards while at the same time permit - but not mandate - a change in the interchange coordination process currently used by the industry.

This document:

1. Reviews the scope of the set of proposed Coordinate Interchange Standards
2. Identifies the entities that perform the Interchange Authority functions today, and
3. Explains how to interpret the proposed Coordinate Interchange Standards for use in today’s world

Scope of Proposed Standards

Standards Focus on Reliability and Coordinate with NAESB's Business Practice and Version 0 Standards

The proposed Coordinate Interchange Standards focus on the reliability issues surrounding the process of approving and implementing energy transfers across Balancing Authority (BA) boundaries (Interchange). Each BA uses Interchange values in calculating its Area Control Error (ACE). The Business Practices for energy transfers across BA boundaries are being developed by North American Energy Standards Board (NAESB). The Coordinate Interchange Drafting Team has been working cooperatively with its counterparts in NAESB to ensure that, to the extent practical, these proposed Coordinate Interchange Standards will not conflict with any associated Business Practices being developed by NAESB.

The NAESB Coordinate Interchange Business Practice (CIBP) Standard identifies market-supported processes to facilitate interchange practices. The NAESB CIBP Standard requires that commercial and reliability data including the necessary front-end business arrangements be obtained by the Purchasing-Selling Entity (PSE) before the PSE submits that Request for Interchange (RFI) to the IA. The IA then uses the NERC Coordinate Interchange Standards to transition the Interchange request from the Market Period to the Reliability Period as shown in Figure 1.

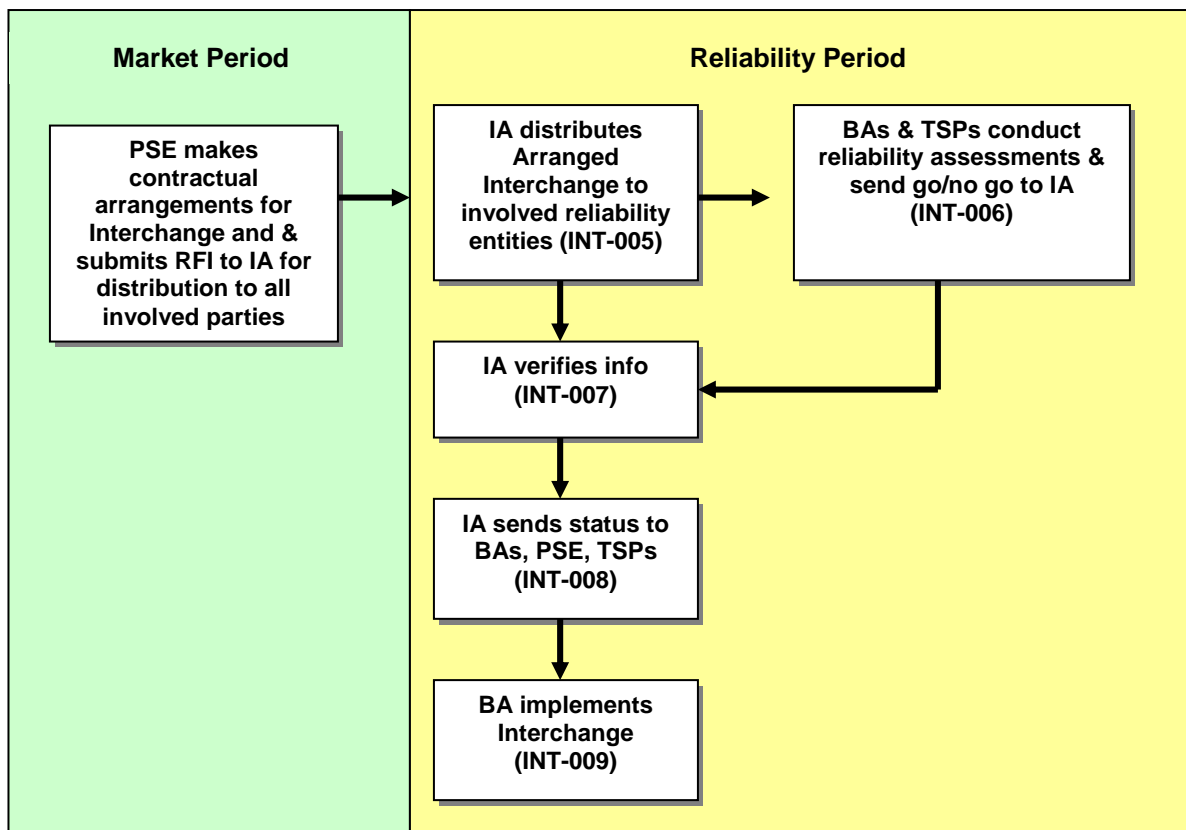

Figure 1

The Six Proposed Coordinate Interchange Standards:

Standard	Title	Description
INT-005	IA Distributes Arranged Interchange	Requires the IA to distribute to all reliability entities involved in the Interchange the information needed for reliability assessment.
INT-006	Response to IA	Requires the BA and Transmission Service Provider to do a reliability assessment of the Interchange and respond to let the IA know if the Interchange should move forward
INT-007	Interchange Confirmation	Requires the IA to verify that Interchange is balanced and valid prior to moving the Interchange forward
INT-008	IA Distributes Confirmation Status	Requires the IA to distribute the status of the Interchange (approved or not) to BAs, TSPs and PSEs.
INT-009	Implementation of Interchange	Requires the BAs to implement Interchange as received from the IA
INT-010	Interchange Coordination Exemptions	Exempts BAs and RCs from following full Interchange coordination process when reliability is at risk

Figure 2

Coordination with Version 0 Coordinate Interchange Standards

There are four Version 0 Coordinate Interchange Standards.

- INT-001 Interchange Transaction Tagging
- INT-002 Interchange Transaction Tag Communication and Assessment
- INT-003 Interchange Transaction Implementation
- INT-004 Interchange Transaction Modifications

The Drafting Team is recommending that portions of each of these standards be either modified or deleted when the proposed Coordinate Interchange Standards are adopted. Some Version 0 requirements duplicate the same requirement in the approved NAESB Business Practice; some Version 0 requirements (which don't have any measures or compliance elements) are duplicated by the requirements in these proposed Coordinate Interchange Standards; some Version 0 requirements don't align with today's practices and aren't measurable; some Version 0 requirements need minor modifications to align with these proposed set of Coordinate Interchange Standards.

For details on the Drafting Team's recommendations for revising, deleting, or retaining the requirements in the Version 0 Coordinate Interchange Standards, reference the Drafting Team's Implementation Plan which is posted on the following web page:

<http://www.nerc.com/~filez/standards/Coordinate-Interchange.html>

Interchange Authority Introduced

The term, “Interchange Authority” was not included in Version 0 Standards – implementation of the IA as a function was postponed because obtaining stakeholder understanding that the “Sink BA” could be the IA would have taken more time than was available for developing Version 0 Standards. This set of proposed Coordinate Interchange Standards provides the first step in implementing the IA function, without requiring changes to today’s practices. Coupled with the proposed revisions to Version 0 Standards and the associated NAESB Business Practice, these Standards provide a comprehensive and cohesive set of requirements for coordinating interchange.

Standards are Performance-Based

Because the proposed Standards are written as “performance-based,” standards, they do not require the use of specific tools, formats or methods to achieve compliance with the standard’s requirements. This is a significant difference from the associated Version 0 Standards. For example, the E-Tagging process addressed in NERC’s Version 0 Standards is not required in the proposed standards, however the use of E-Tags is not precluded and is, in fact, accommodated by the proposed Standards. Similarly, manual processes such as the use of email, a phone, a fax, or any other mechanism is not precluded. This is consistent with the Standards’ goal of focusing on reliability “performance,” rather than the tools used to support that performance.

Proposed Standards Limited to Interchange Between Balancing Authorities

These standards focus on Interchange that crosses BA boundaries. INT-001, Requirement 1.2 that required the creation of Arranged Interchange for energy transfers internal to a BA was removed per recommendation of NERC’s Interchange Subcommittee and Operating Reliability Subcommittee. The removal of this requirement does not preclude the development of Regional or individual Reliability Coordinator requirements for the creation of Arranged Interchange based on special circumstances. In addition, business practices beyond the scope of these reliability standards may continue to require the creation of Arranged Interchange.

Internal Interchange Activities

The Functional Model does not treat internal interchange that occurs within an energy market or within a Regional Transmission Operator (RTO) in a special manner. For example, a Scheduling Agent that provides approved interchange instructions to internal BAs within an RTO market structure is assumed in this set of standards to function as a BA’s agent in its interactions with the IA. (See Functional Model Version 2 companion Technical Document Section 2.6 – Technical Discussion – Managing Bi-lateral Transactions – Scheduling Agents).

Identifying the Entities that Perform the Interchange Authority Tasks Today

Who Performs the Interchange Authority Function Today and in the Future?

Under the Functional Model, interchange tasks assigned to the Interchange Function are performed by an IA. Today, in Version 0 Standards, the process of reviewing and approving Interchange is the responsibility of the “Sink BA”. In practice, the Sink BA uses the E-Tag system to obtain Interchange approvals. Under these proposed Standards, the implementation of the IA would take the approach recommended in the report to the Operating Committee from the IA Implementation Task Force (IAITF) of the Interchange Subcommittee.

(<http://www.nerc.com/~filez/is.html>) As the IAITF reports indicates, the function of the IA would most likely be filled by the same organization which performs the Sink BA functions today and which operates a Tag Authority under the electronic tagging process.

A different implementation of the Interchange Function and the entity performing that IA Function may evolve over time. Industry discussions and the long-term recommendations of the IA Implementation Task Force have included a single Interconnection-wide IA as a possibility in the future.

Number of Interchange Authorities

Neither the Functional Model nor this set of proposed Standards imposes any upper or lower limit on the number of Interchange Authorities that can exist. These Standards only require that an IA be involved in coordinating Interchange. Although the Standards do not impose any expectations on the implementation of the IA, some type of standard industry practice is expected to evolve.

Relationship to Functional Model

The proposed Standards are generally based on Version 2 of the Functional Model. Due to the ongoing discussion within the industry on the nature and content of a Version 3, the Drafting Team has taken an “evolutionary” approach to implementation of the Functional Model in the proposed Coordinate Interchange Standards. The Functional Model Version 2 has been used as the vision or goal for development of the Standards. A precise implementation of the Version 2 would be a more “revolutionary” approach than the industry has indicated it is ready to accept. Therefore, the implementation of the IA has taken the approach recommended in the report from the IAITF where the IA in the foreseeable future would provide more of a “coordinating” role rather than an “authoritative” role. BA’s would still perform pre-implementation schedule checkout as required in INT-003, Requirement 1 rather than rely solely on the authoritative direction of an IA.

In addition to the implementation of the IA which varies from the current Version 0, the Drafting Team has increased the role of the Transmission Service Provider (TSP) to ensure prevailing transmission system limits are not violated. In the Coordinate Interchange SAR and in the Functional Model this reliability approval activity was to be performed by the RA. Recent discussions within the industry have indicated that full implementation of the RA as defined in the Functional Model will occur sometime in the future and the new standards will not include the RA at this time. These new standards will include the industry’s existing Reliability Coordinators (RCs) and their existing functionality. RC’s today do not see individual electronic tags during the approval process but see them in composite once they are approved. In proposed INT-006, the RC has been removed from the approval process. Compliance with system operating limits is considered to be part of the TSP approval process as the TSP confirms transmission service arrangements for the Arranged Interchange. The TSP is not assumed to be setting the limits but

in its role as provider of transmission service it must be aware of prevailing limits. This is particularly true in the case where transmission service for an Interchange may have been obtained many days or even months in the past but the Arranged Interchange may now violate a limit which could be more restrictive than that used when the transmission service was first reserved.

Interpreting the Proposed Coordinate Interchange Standards

Terminology

Functions Assigned Responsibility for Proposed Standards

Responsible entities used in these standards and this companion Reference Document are:

- Interchange Authority
- Balancing Authority
- Transmission Service Provider
- Purchasing-Selling Entity
- Reliability Coordinator

Note that the proposed standards use the term, “Reliability Coordinator,” rather than the Functional Model term, “Reliability Authority.” The Standards Authorization Committee (SAC) directed all drafting teams to stop using the term, “Reliability Authority.” The term, “Reliability Coordinator” is in use today, and the confusion surrounding the “Reliability Authority” would delay implementation of the standards.

Also, note that the terms, “Scheduling Entity” or, “Scheduling Agent” are not used in the proposed standards. These terms are not associated with a Functional Model Version 2 entity. The drafting team assumes that the Scheduling Entity either:

- Has registered as a BA, or
- Has signed a “delegation agreement” and has agreed to perform some tasks for a BA.

Terms Associated with Interchange, Transactions, Schedules

The industry currently uses the terms “*interchange*” “*transactions*” and “*schedules*” interchangeably to mean very different things. The Drafting Team tried to correct the misunderstandings associated with these terms by developing precise definitions associated with the various states in the decision making process that results in the data that is entered into the “Net Scheduled Interchange” portion of the Area Control Error (ACE) equation. The definitions selected attempt to reflect the state or nature of the Interchange at any point in the reliability period. The term “*schedule*,” for example, represents the time qualities of the Interchange (i.e. MW values at a point in time for a BA) but may not represent other characteristics such as transmission service arrangements, source, sink, etc. Similarly, the term “*transaction*,” has the connotation of a business arrangement. To avoid this problem, an “adjective naming” approach was chosen to describe the Interchange.

To understand the terminology used by this standard, refer to Figure 3, which shows the various stages in the life cycle of Interchange as addressed in these standards. The portion of the Interchange process addressed by NAESB Business Practices is shown in the green box and occurs in the “Market Period.” The portion of the Interchange process addressed by reliability standards is shown in the yellow box and occurs in the “Reliability Period.” Note that E-tagging occurs during the “Reliability Period.”

Request for Interchange (RFI): A collection of data as defined in the NAESB RFI Datasheet, to be submitted to the Interchange Authority for the purpose of implementing bilateral Interchange between a Source and Sink BA.

Interchange: Energy transfers that cross Balancing Authority boundaries.

Arranged Interchange: The state where the Interchange Authority has received the Interchange information (initial or revised).

Confirmed Interchange: The state where the Interchange Authority has verified the Arranged Interchange.

Implemented Interchange: The state where the Balancing Authority enters the Confirmed Interchange into its Area Control Error equation. (Note: Implemented Interchange first becomes “implemented” when it is initially entered into the ACE equation but remains in that state until the whole profile is completed at the designated stop time since it continues to be reflected in the ACE equation until that point. It is the profile transitions (initial ramp and subsequent ramps) which the “BA-BA Checkout” required in INT-003, Requirement 1 is intended to confirm and coordinate prior to their reflection in the ACE equation)

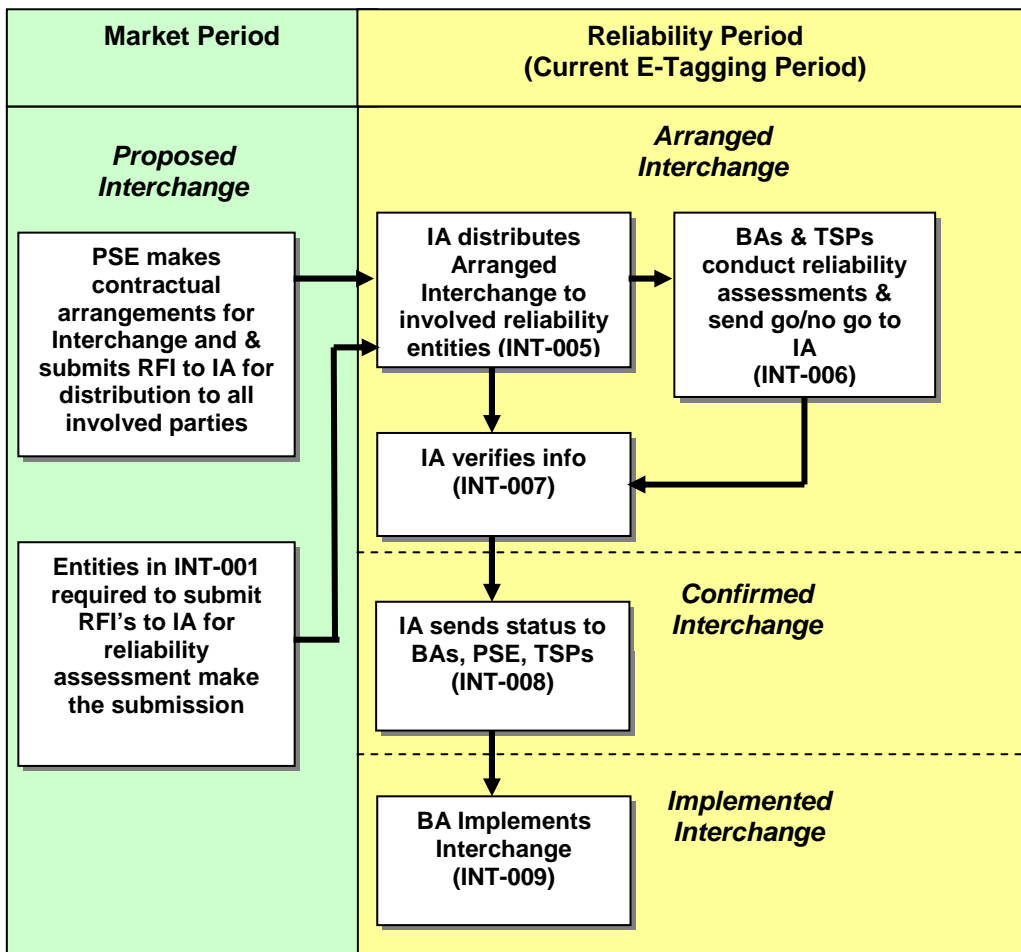

Figure 3

During the Market Period stage of this process the data needed for the Request for Interchange is compiled by market participants and is outside the scope of this standard. In the Market Period stage, the PSE puts together the business arrangements for the interchange with TSPs, Generators and LSEs and may obtain preliminary reliability approvals from BAs and TSPs and RCs where required. At this stage, agreements (including transmission reservations) can be put together in a piecemeal fashion – but these business arrangements do not become an “Arranged Interchange” until all the involved TSPs and BA’s give their preliminary approval to the PSE. These preliminary steps in the process were not included in the scope of the SAR and aren’t included in this draft standard.

These standards cover the reliability-related aspects of the confirming and implementing Interchange steps. These standards imply that prior to becoming an Arranged Interchange all business requirements are settled; otherwise, the PSE would not receive consent from all the entities and the life cycle of the proposal would end before entering the reliability stages — those stages directly addressed by these standards.

While these standards cover the reliability-related aspects of Interchange confirmation and implementation, current tools (E-Tag) and business practices may require the entity performing the IA distribution activities in INT-005 of these standards to also distribute the Arranged Interchange to market entities for review and approval during the same assessment period identified for reliability entities in INT-006. This “dual” reliability/market role of the IA in the distribution process is not in contradiction to its reliability role; actually facilitates real-world tools and process efficiency; and reflects the practical need for continued coordination between NERC Standards and NAESB business practice implementation.

Additional Terms Associated with the Interchange Standards

Included in the standards are other terms that may require some clarification based on discussions within the Drafting Team and comments received during the posting process.

Energy Sharing Agreement: This generic term is intended to reflect those agreements that permit interchange activity to take place between two entities for “emergency” type situations. Examples of this would be reserve sharing agreements and terms in some Interchange Agreements that permit emergency interchange.

Imminent Risk: The use of this term in INT-010 is intended to reflect those conditions typically viewed as “emergency,” i.e. having immediate, significant system risks and where response time is of the essence. The term “emergency” was avoided, however, since it has specific interpretations and often contractual implications. The “imminent risk” term was generic enough to avoid such complications. The term “imminent risk” was NOT intended to cover those conditions where “curtailment” are used to affect Interchange modifications since such modifications are commonly viewed as necessary from a reliability perspective but are not as time-critical as an emergency (e.g. E-Tag approval processing and timing can still take place).

NERC-identified Reliability Tool: This generic term is intended to reflect in a “tool neutral” manner those wide-area reliability assessment tools (such as the Interchange Distribution Calculator for the Eastern Interconnection) acknowledged by NERC as a decision making tool among various reliability entities. This was to differentiate it from other more numerous, local tools so that the IA would be limited in the locations to which it is required to distribute Confirmed Interchange statuses.

Timing

Stakeholders indicated in their comments that some guidance is expected concerning the times allowed to complete the various steps in the process of coordinating and implementing Interchange. The Drafting Team used the Timing Tables from INT-001 Attachment 1 as a guide to establish time frames that permit sufficient time to complete a task while also leaving enough time for other entities to complete the remaining subsequent tasks. The timing table provides structure so that one entity will not cause another entity to fail its subsequent requirements due to deliberate or inadvertent delays.

The Drafting Team changed the reference point of the timing requirements from the “Start” of a Transaction to the “Ramp Start.” This change permitted various ramp times while allowing for a consistent reliability assessment period regardless of the ramp period. In addition, the current Eastern and Western Interconnection timing requirements were consolidated into a single reliability-related timing table.

The timing table developed for the proposed Coordinate Interchange Standards is shown on the following page.

INT-010 identifies exemptions from the normal reliability assessment period Interchange process specified by INT-005 through INT-009 and the associated timing issues related to those exemptions. For the cases of an energy sharing agreement and the mitigation of an imminent reliability problem by an RC, the submission of an Arranged Interchange may be delayed as described in the Standard from the timing noted in the timing table shown on the next page.

Typical activities which will take place during each of the timing periods noted in the Timing Table are:

- Column A – IA Makes Initial Distribution of Arranged Interchange – The IA receives and distributes the Arranged Interchange to all the reliability entities involved in the Interchange. During this same time period (prior to distribution), in some implementations (e.g. E-Tag), the IA may also perform some of the verifications required in INT-007 Requirements 1.1 through 1.3.
- Column B – BA and TSP Conduct Reliability Assessments, IA Verifies Reliability Data Complete – The BA and TSP perform the required reliability assessments necessary to respond appropriately (approve or deny) to an Arranged Interchange. Those assessments required of the BA and TSP are shown in INT-006 but other assessments could also be required on a Regional or local basis. During this period the IA also completes the verification of the data required in INT-007, Requirements 1.1 through 1.3.
- Column C – IA Compiles and Distributes Status – The IA completes the determination of whether to transition Arranged Interchange to Confirmed Interchange based on the information verified from INT-007, Requirements 1.1 through 1.4. The IA then distributes to all appropriate parties the composite final status of whether the Interchange was approved or denied.
- Column D – BA Prepares Confirmed Interchange for Implementation – Upon receipt of the Confirmed Interchange from the IA, the BA provides the Interchange information to the appropriate scheduling tools to affect the Net Scheduled Interchange in its ACE equation. The BA also performs the “BA-BA checkout” required in INT-003 to confirm the coordination of the new Interchange with its neighboring BA’s.

Timing Table

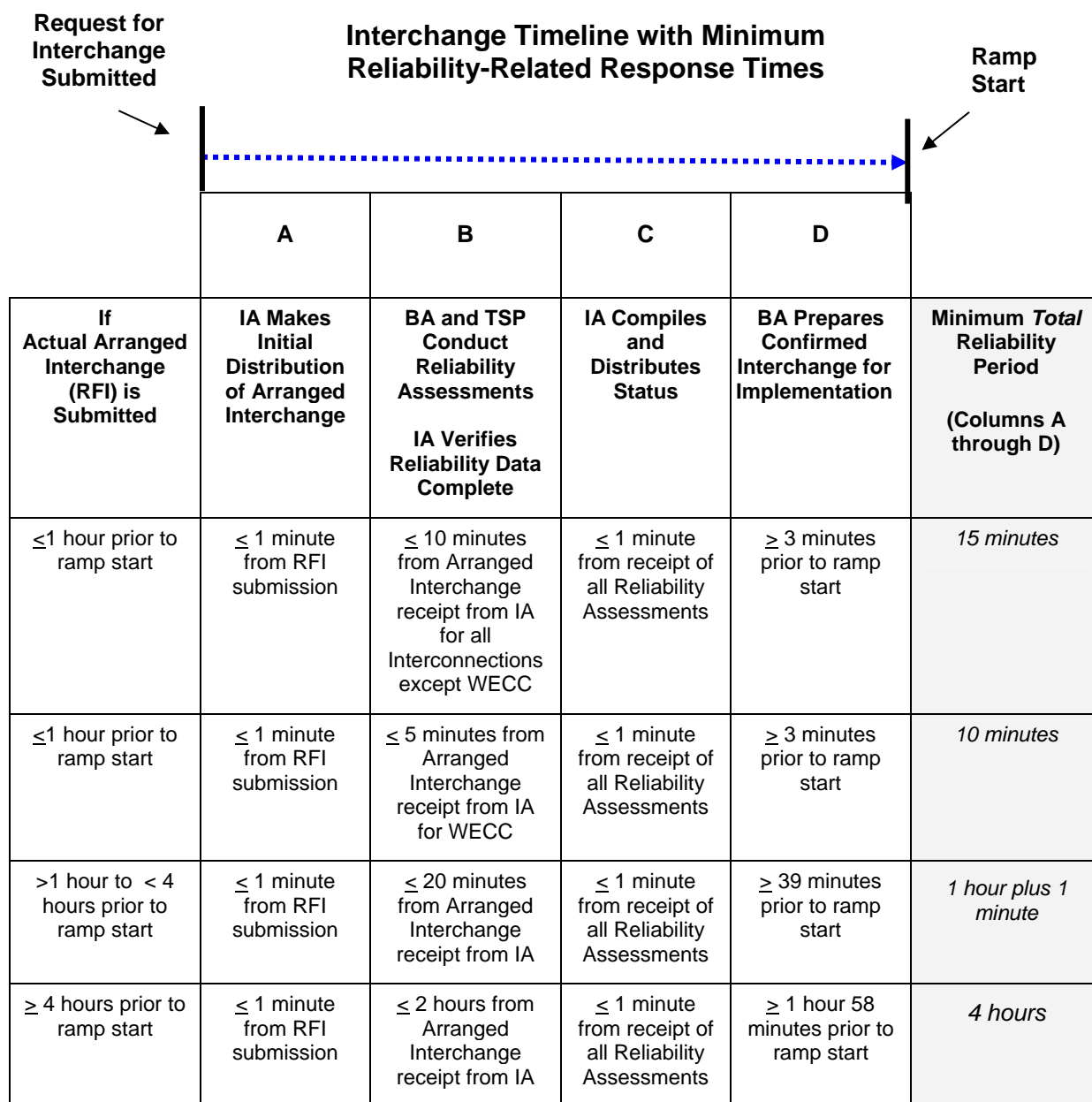

Figure 4

How will the practicalities of timing be addressed?

The timing periods provided in the standards are there to ensure that under most circumstances, entities will have sufficient time to perform the required reliability activities. There will be times that completion of a task can not be completed due to extenuating circumstances. In these cases, as envisioned, if a function’s timing is not met, the Interchange will not be approved to become an Implemented Interchange. Local agreements (e.g. pre-approvals or denials) for handling timing issues which still comply with other reliability standards’ obligations yet which still ensure coordinated interchange during constrained timing compliance situations are not prohibited by these standards. Similarly, the current practice of “passive approval” although not explicitly described is also not

prohibited. The Standard INT-006 compliance for a BA/TSP response to an IA request for reliability assessment allows for agreements (which can include “passive approval”) between an IA and a BA/TSP for documenting that a “response” to an IA has been provided. The use of passive approval does not relieve the BA or TSP of its requirement to perform a reliability assessment of an Arranged Interchange.

Dynamic Schedules

The use of dynamic schedules is a type of bilateral interchange that is covered by the requirements of this standard. The Implemented Interchange defined by the telemetered quantities associated with a dynamic schedule is applied to the Net Scheduled Interchange term of the ACE equation.

The current tagging requirements for a dynamic schedule by the PSE and the adjustment by the PSE when the hourly projected dynamic schedule varies outside the prescribed bounds are found in INT-001 and INT-004, respectively. The Drafting Team recommends that these Version 0 requirements remain in effect since they are outside the bounds of the Drafting Team’s SAR.

Pseudo-Ties

The use of pseudo-ties requires that both BAs include the actual telemetered qualities in the Net Actual Interchange component of the ACE equation; therefore, pseudo-ties are not included in the standard.

DC Ties

DC ties are addressed in standard INT-009, Requirement 1 and how they are treated for Interchange is measured in INT-009, Measure 1.2. The standard handles the different ways BAs handle DC ties in their ACE equation as follows:

- If a BA is directly connected to a DC tie and includes the DC tie flow in the Net Scheduled Interchange component of its ACE equation, then, the DC tie Interchange is treated the same as any other Interchange.
- If a BA is directly connected to a DC tie and models the tie as load or generation in its area, the interchange on the DC tie is not included in the Net Scheduled Interchange component of the ACE equation. (In this case, the Interchange is balanced internally like any other load or generation and doesn’t cross BA boundaries.)
- In the case of “flow through” Interchange, the BA connected directly to a DC tie would need to include the Interchange in the Net Scheduled Interchange component of its ACE equation, because it would be receiving or delivering energy with other BAs across AC interfaces.

In all cases noted above, the BA that operates the DC tie would receive the Interchange information and be subject to the standard and responsible for notifying the IA of a DC tie trip and the associated Interchange change.

The “Normal” Process of Coordinating Interchange

Figure 5 below shows the normal, reliability-related steps in coordinating Interchange, starting when the Request for Interchange (RFI) is submitted to the IA, through the Reliability Assessment period, to the point where the IA distributes the Interchange status and the Interchange information is entered into the NERC-identified reliability tool and the ACE equations. Note that the RFI shown in Figure 5 may come from normal market processes covered by NAESB Business Practices or from those situations required in INT-001.

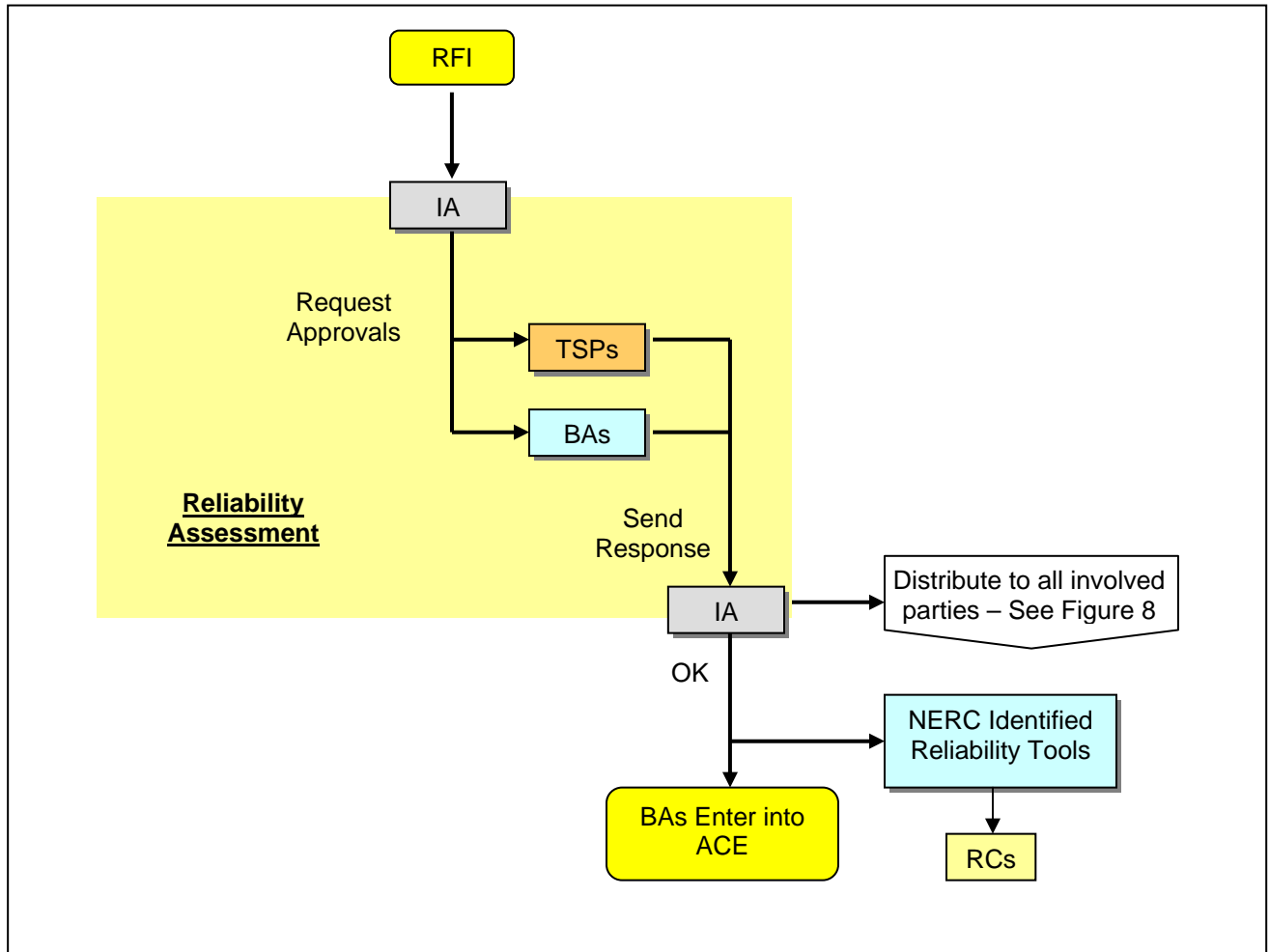

Figure 5

Interchange Changes for Reliability Reasons

Once an Interchange has transitioned to the Confirmed or Implemented states, it is entirely possible that the Interchange parameters (i.e. MW, ramp start and stop, duration, etc.) may need to change for reliability reasons. The change to an Interchange in one of these states does not eliminate the necessity for coordination. While Figure 5 shows the coordination that takes place when an Interchange is initially established, Figure 6 shows coordination steps to effect a change to an Interchange that has already been transitioned to Confirmed Interchange or Implemented Interchange.

Interchange modifications covered in INT-010 initially do not follow the transition shown in Figure 6. Interchange created or modified to resolve an imminent reliability risk or as part of an energy sharing agreement is implemented first, and then follows the submission and transition steps shown in Figure 6.

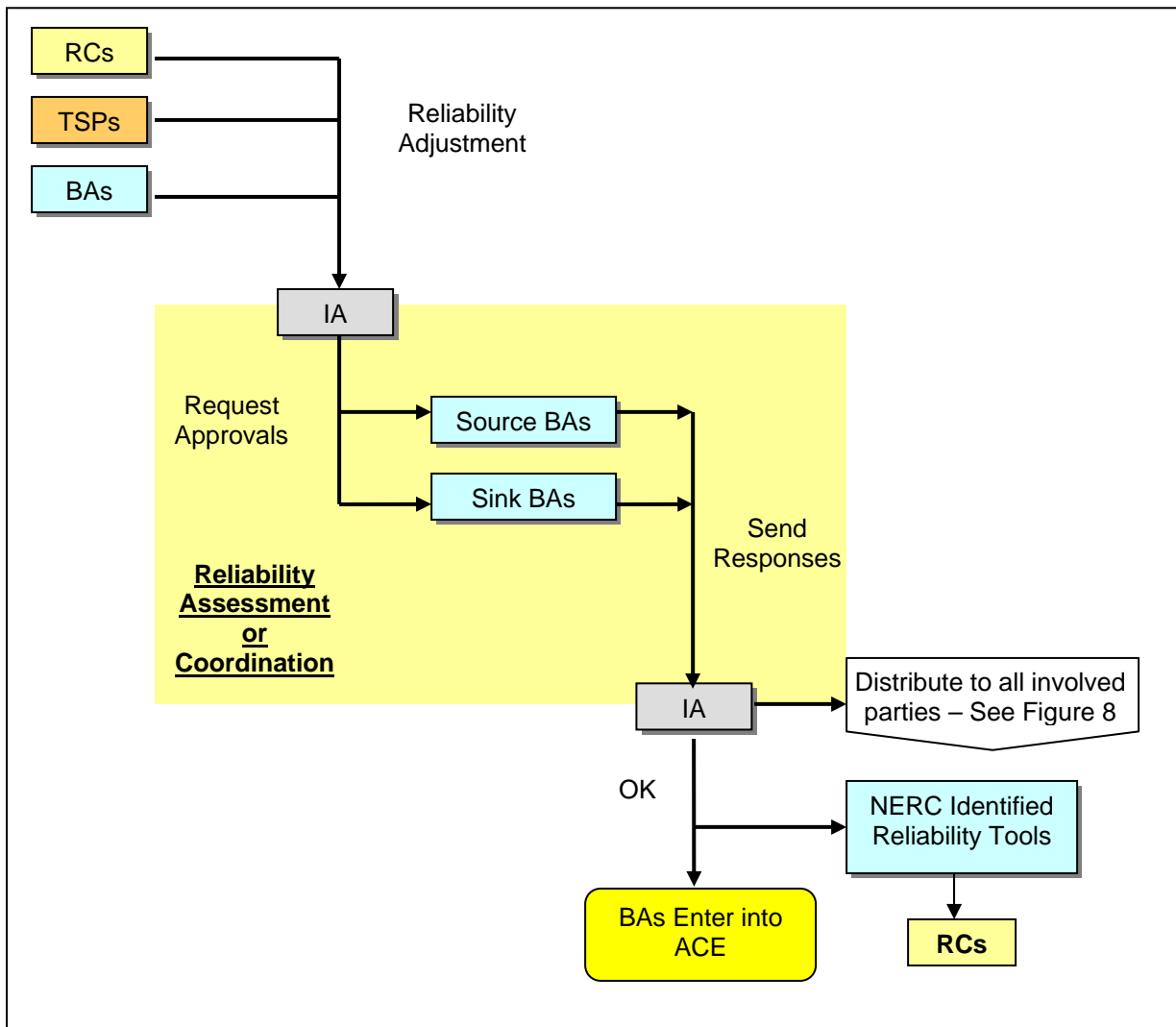

Figure 6

Interchange Changes for Market Reasons

Figure 7 shows a change (e.g., cancel, increase MW, decrease MW, change ramp or duration info, etc.) initiated by the PSE or Market Authority¹ (MA) for non-reliability reasons once the Interchange has transitioned to a Confirmed Interchange. In this case, the PSE or MA will make the same type business and reliability arrangement communications that it did for the initial Request for Interchange. Subsequent steps also follow the same process. Although not shown, if an Interchange has already transitioned to an Implemented Interchange state, the same steps taken during the original coordination (see Figure 5) would be taken by the PSE or MA and IA.

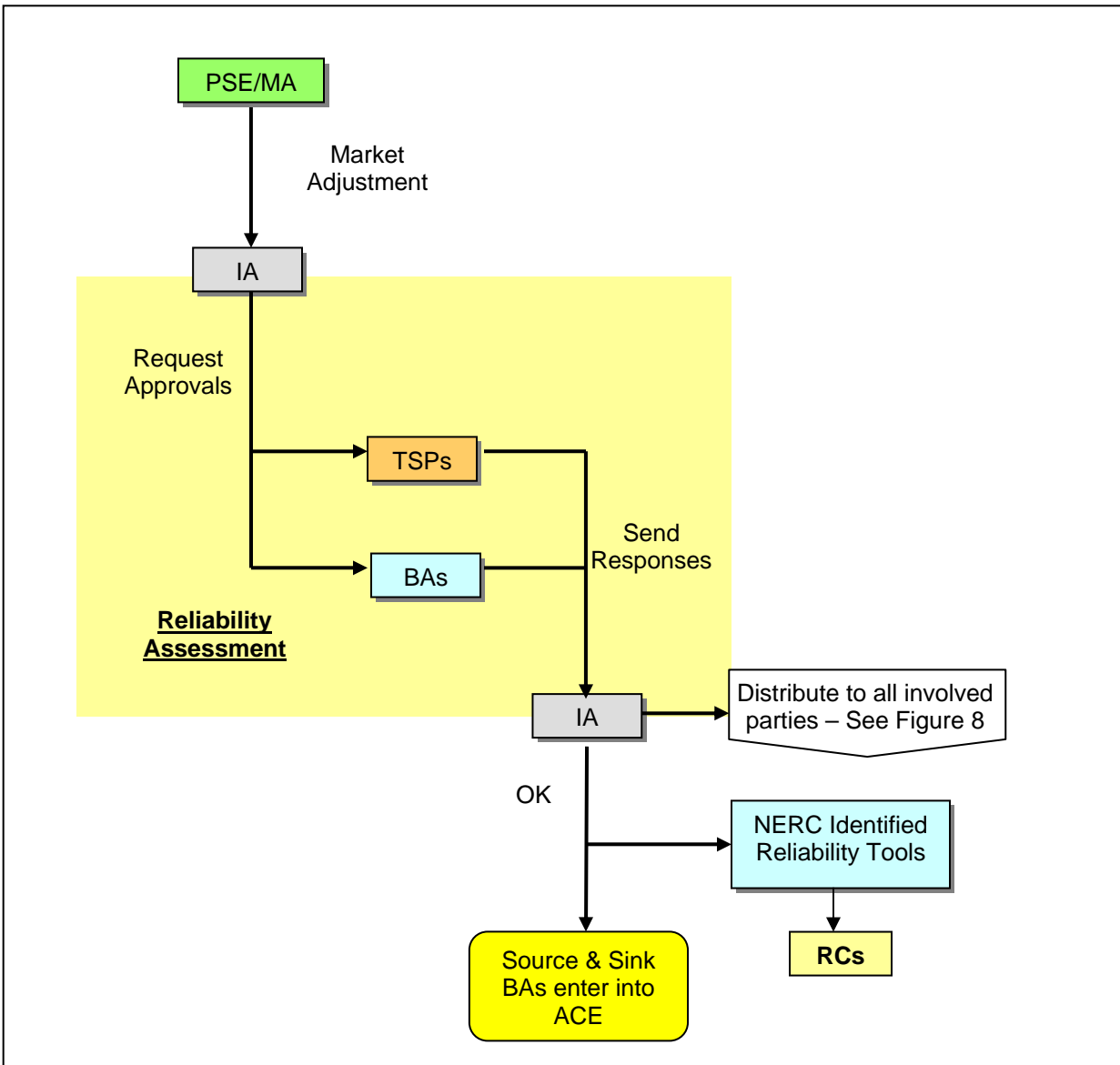

Figure 7

¹ MA is an acronym for Market Authority, Market Assembly or Market Assessment – This allows an automated system to build the Interchange for submission.

Figure 8 shows the IA communicating the status of the Interchange to all parties involved in the transaction.

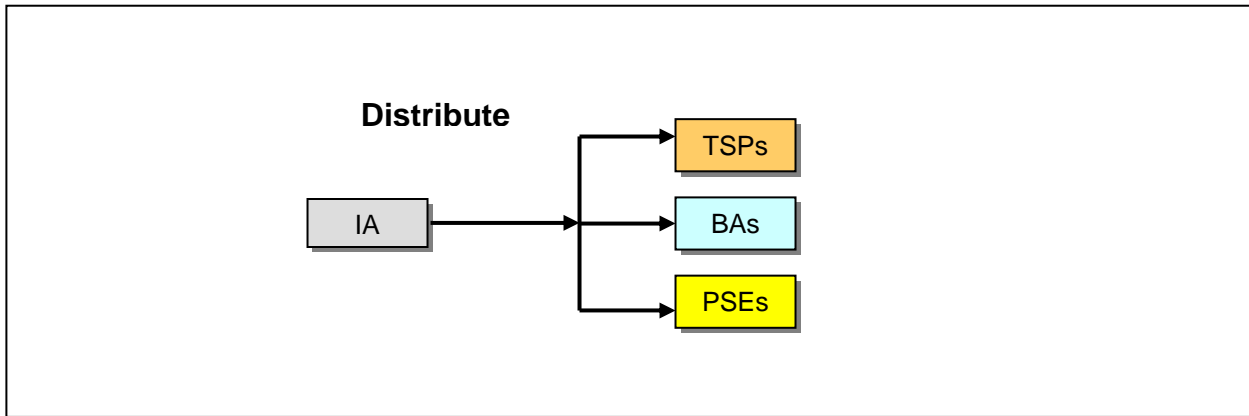

Figure 8