

Work Paper for Title Transfer Tracking Standards

PROPOSED STANDARDS REGARDING TITLE TRANSFER TRACKING **WorkpaperStandards Remaining to be Addressed Version**

Proposed Standards, Definitions, and Principles:

P1

Title Transfer Tracking (TTT) by Third Party Account Administrators (3PADs) should not include transfers of gas between storage service accounts or transfers between Transportation Service Agreement contracts on the same Transportation Service Provider (TSP) with no physical receipts or deliveries required to effectuate the contract-to-contract transfer.

Additionally, where TSPs do not provide pool-to-pool transfers, TTT by 3PADs at pool locations should be allowed. Where TSPs do provide pool-to-pool transfers, TTT by 3PADs at these pooling locations can be excluded by the TSP [unless the 3PAD can conform to nomination deadlines].

Pool-to-pool transfers or contract-to-contract transfers on the same TSP are nominated to the TSP at nomination deadlines.

[Bracketed section is bookmarked until End Users can discuss](#)

S9

Failure of a Title Transfer Tracking Service Provider to:

- a) provide the applicable Transportation Service Provider (TSP) an unsolicited Request for Validation (or a Validation Response in response to a Request for Validation), as applicable to a Third Party Account Administrator for its Account Holder's transaction, or
- b) perform a similar validation process, as applicable to a TSP providing Title Transfer Tracking service, for its Account Holder's transaction,

can result in the failure of the subject transaction to be confirmed and scheduled by the TSP. *(answers open issue G) Original #9. Diagram relationship Lines V and W (requests); U and D (response)*

[7/17/98 - Bookmark until after timeline discussion](#)

S14

Title Transfer Tracking service should be accomplished by using the nomination-related, flowing gas-related, invoice-related and electronic delivery mechanism-related GISB standards with codes and values appropriate to Title Transfer Tracking services.

(answers open issue B) Original #18

[Bookmark pertaining to possible instructions to IR, or as a possible standard](#)

S15 – Defer to timing discussions

Third Party Account Administrators (3PAD) should send initial unsolicited Confirmation Responses, for transactions into and out of their location(s) and/or agreements, to the associated TSP, so that they are received at the TSP's designated site by no later than one hour following the nominations deadline applicable to Account Holders and Service Requesters. A 3PAD should initiate a confirmation by sending a Confirmation Response or an unsolicited Confirmation

Work Paper for Title Transfer Tracking Standards

Response so that it is received at the TSP's designated site within one hour of the 3PAD learning of any change to transactions into or out of their location(s) and/or agreement(s), and the 3PAD should respond (with a Confirmation Response) to any subsequent Request for Confirmation sent by a TSP so that it is received at the TSP's designated site within thirty minutes of receipt of such Request for Confirmation at the 3PAD's designated site.

(answers open issue C) Original #19 Diagram relationship Lines G's, H, X's, and Y's

S16

For purpose of the Confirmations, Scheduling and Allocations processes, the Third Party Account Administrator (3PAD) and Transportation Service Provider (TSP) should exchange information as follows:

- a) for receipts into the 3PAD, the information should be delineated at the level of the TSP's applicable Service Requester or Upstream Identifier (i.e., party) and the 3PAD's Account Holder receiving gas from such Service Requester or Upstream Identifier party; and,
- b) for deliveries out of the 3PAD, the information should be delineated at the level of the 3PAD's Account Holder and the TSP's applicable Service Requester or Downstream Identifier (i.e., party) receiving gas from such Account Holder."

(answers open issue A) Old #20

Jim and Sylvia will reword

Bookmarked pertaining to possible instructions to IR, or as a possible standard

S17

Absent mutual agreement to the contrary, when a Third Party Account Administrator (3PAD) has previously sought to confirm with a Transportation Service Provider (TSP) a transaction with respect to a location(s) or agreement and there is no transaction with respect to such location(s) or agreement applicable to the then current period, the 3PAD should send an unsolicited Confirmation Response to the TSP indicating that there are no transactions to be confirmed for the current period with respect to such location(s) or agreement. *(answers open issue A)*

Original #21 Diagram relationship Lines X's and Y's

S23

The Title Transfer Tracking Timing and Information Flow Diagram (the TTT TIF Diagram) represents the movement of information between parties with respect to processing (from nomination through scheduled quantity) a given Title Transfer Tracking transaction.

Transmittals of information are identified by lines labeled with letters. Some of the lines identified with letters are intended to be logical branches to processes which involve transmittals of information between parties. In addition, processes where information is compared with other information or otherwise processed in order to generate a transmittal are identified by boxes labeled with numbers.

[Diagram here]

Work Paper for Title Transfer Tracking Standards

**Title Transfer Tracking
July 9, 1998
Timing / Flow Diagram**

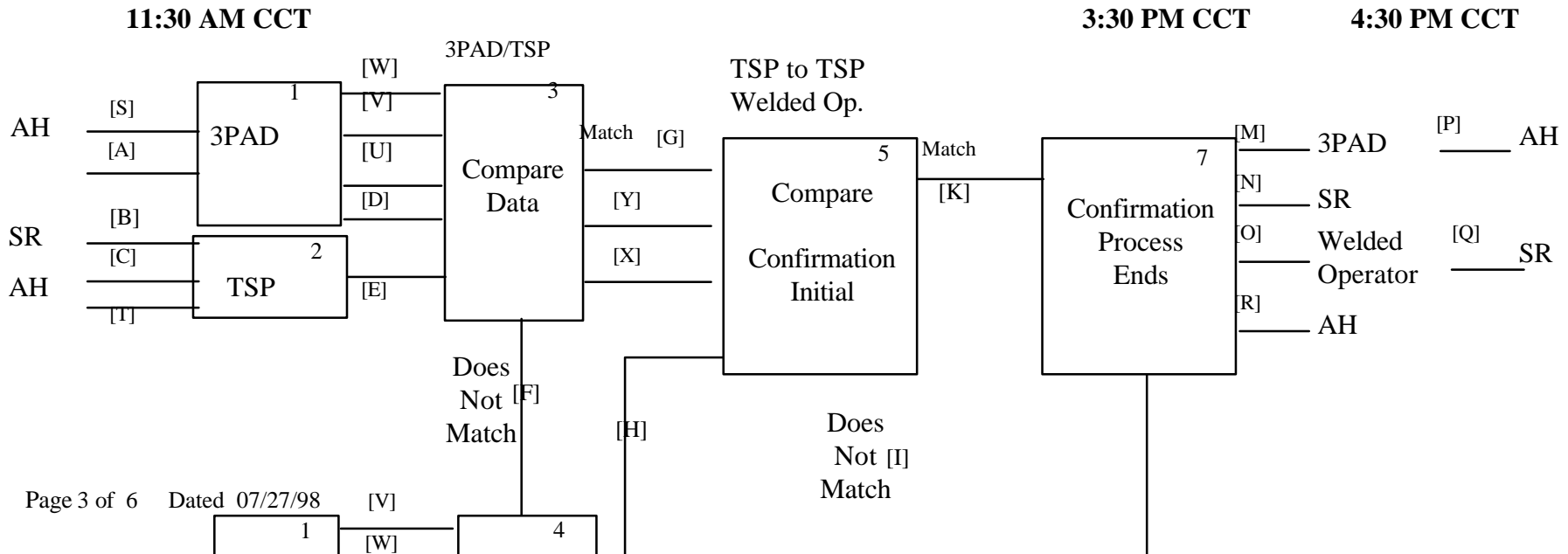

Work Paper for Title Transfer Tracking Standards

In the TTT TIF Diagram, the boxes represent processes performed by the entity listed below:

- Box 1: Third Party Account Administrator
- Box 2: Transportation Service Provider performing TTT services as well transportation
- Box 3: Transportation Service Provider
- Box 4: Transportation Service Provider
- Box 5: Welded Operator
- Box 6: Transportation Service Provider
- Box 7: Transportation Service Provider
- Box 8: Welded Operator

In the TTT TIF Diagram, lines represent transmittal of the transaction listed below:

- Line A: Title Transfer Nomination (to 3PAD)
- Line B: Transportation Nomination (to TSP)
- Line C: Title Transfer Nomination (to TSP acting as TTTSP)
- Line D: Title Transfer Request for Validation (from 3PAD to the TSP)
- Line E and F: do not represent documents
- Line G: Request for Confirmation (from TSP to WOper)
- Line H, I, J, K and L: do not represent documents
- Line M: Operator Scheduled Quantity (from TSP to 3PAD)
- Line N: Scheduled Quantity Information (from TSP to SR)
- Line O: Operator Scheduled Quantity (from TSP to WOper)
- Line R: Scheduled Quantity Information (from TSP to AH)
- Line P: Scheduled Quantity Information (from 3PAD to AH)
- Line Q: Scheduled Quantity Information (from WOper to SR)
- Lines S: Title Transfer Nomination Quick Response Information (from 3PAD to AH)
- Line T: Title Transfer Nomination Quick Response (from TTTSP to AH)
- Line U: Title Transfer Request for Validation Quick Response (from TSP to 3PAD)
- Line V: Title Transfer Validation Response (from TSP to 3PAD)
- Line W: Title Transfer Validation Request Quick Response (from 3PAD to TSP)
- Line X: Request for Confirmation and Unsolicited Confirmation Response (from TSP to WOper)
- Line Y: Confirmation Response (from WOper to TSP)

This standard may be modified as the diagram is cleaned up to clearly designate parties and processes

S24.1

With respect to the TTT TIF Diagram:

- a) the line D from Box 1 to Box 3 should be received at the Transportation Service Provider's Designated Site within one hour of the nomination deadline;
- b) the line V from Box 3 to Box 1 should be received at the Third Party Account Administrator's Designated Site within one half hour (30 minutes) of the receipt of the Title Transfer Request for Validation; and,
- c) the line U should be received at the applicable receiver's Designated Site within fifteen (15) minutes of receipt at the sender's Designated Site of the transmittal to which the quick response responds.

Work Paper for Title Transfer Tracking Standards

Note: The Section C may contain a Line W transmittal depending on the outcome of the “parked” issue of Title Transfer Validation Response Quick Responses (D10).

S24.2

With respect to the TTT TIF Diagram; line “F” between Box 3 (representing a process at the TSP) and Box 4 (representing a process at the TSP which resulted in the identification of a mis-match between the transactions nominated to the TSP from its Service Requesters (and/or Account Holders) as entering or leaving the 3PAD from or to (respectively) the TSP, and, those transactions identified by the 3PAD to the TSP in line “D” between Box 1 and Box 3 above) should promptly begin another exchange of information between the TSP and the 3PAD. This other exchange of information is that identified as being conducted between Box 4 and Box 1 and should be comprised of (in order) the information to be exchanged in lines V, W, D, V, and W.

S24.3

With respect to the TTT TIF Diagram; the line “D” transmittal (a TTRFV) between Box 1 (representing a process at the 3PAD) and Box 4 (representing the mis-match result at the TSP from comparing its and the 3PAD submitted information) should be received at the TSP’s designated site within one half of an hour of the receipt of the line first “V” transmittal (a TTVR) between Box 4 and Box 1. This first “V” line transmittal should identify that it is the result of a mis-match, and should identify the mis-matched line item(s). The second line “V” transmittal (a transmittal following receipt and processing of the line “D” between Box 1 and Box 4) should be received at the 3PAD’s designated site within one half of an hour (30 minutes) of the receipt of the TTRFV (the line “D” transmittal). In addition, the line “W” transmittals (the TTVR-QRs between Boxes 1 and 4) should be received at the TSP’s designated site within fifteen (15) minutes of receipt at the 3PAD’s designated site of the transmittal to which the quick response responds.

S24.4

With respect to the TTT TIF Diagram; line “I” between Box 5 (representing a process at the TSP) and Box 6 (representing a process at the TSP which resulted in the identification of a mis-match between the transactions nominated to the TSP from its Service Requesters (and/or Account Holders) as entering or leaving the Welded Operator from or to (respectively) the TSP, and, those transactions identified by the Welded Operator to the TSP in line “Y” between Box 5 and Box 3 above) should promptly begin another exchange of information between the TSP and the Welded Operator. This other exchange of information is that identified as being conducted between Box 6 and Box 8 and should be comprised respectively of the information to be exchanged in lines G, X, and Y.

S24.5

Where the results of the comparison of information presented as the transmittals between Boxes 6 and 8 cause a reduction to a quantity identified by the TSP to a 3PAD in last corresponding line “V” transmittal (line “J” exemplifies this occurrence), the TSP should promptly begin another exchange of information between the TSP and the 3PAD. This other exchange of information is that identified as being conducted between Box 4 and Box 1 and should be comprised of (in order) the information to be exchanged in lines V, W, D, V, and W.

Work Paper for Title Transfer Tracking Standards

S24.6

With respect to the TTT TIF Diagram; the line “G” transmittal (a RFC) between Box 3 (representing a process at the 3PAD) and Box 5 (representing a process at both the TSP and the Welded Operator respectively) should be received at the applicable party’s designated site within two hours of the nomination deadline; the line “X” transmittal (a CR) between Box 5 and Box 3 should be received at the applicable party’s designated site within one half of an hour (30 minutes) of the receipt of the RFC and the line “Y” transmittal (the CRQR between Box 6 and 8) should be received at the applicable receiver’s designated site within fifteen (15) minutes of receipt at the sender’s designated site of the transmittal to which the quick response responds.

S24.7

With respect to the TTT TIF Diagram; at the time of any line “D” transmittal (a TTRFV) between Box 1 (representing a process at the Third Party Account Administrator (3PAD)) and either Box 3 or Box 4 (both representing a process at the Transportation Service Provider (“TSP”)) the information in the transmittal as to the total quantities into and total quantities out of the 3PAD from and to the TSP respectively should be equal to one another.

S24.8

With respect to the TTT TIF Diagram; at the time of any line “G” transmittal (a RFC) sent by a TSP to a Welded Operator the information in the transmittal as to the total quantities into and total quantities out of the Welded Operator from and to the TSP respectively should reflect the processing of 3PAD provided information as to activity on the TSP side of the TSP/Welded Operator interconnect including the netting out of transactions across 3PADs (if applicable).

S24.9

With respect to the TTT TIF Diagram; at the time of any line “X” transmittal (a CR) sent by a TSP to a Welded Operator the information in the transmittal as to the total quantities into and total quantities out of the Welded Operator from and to the TSP respectively should reflect the processing of 3PAD provided information as to activity on the TSP side of the TSP/Welded Operator interconnect including the netting out of transactions across 3PADs (if applicable).