

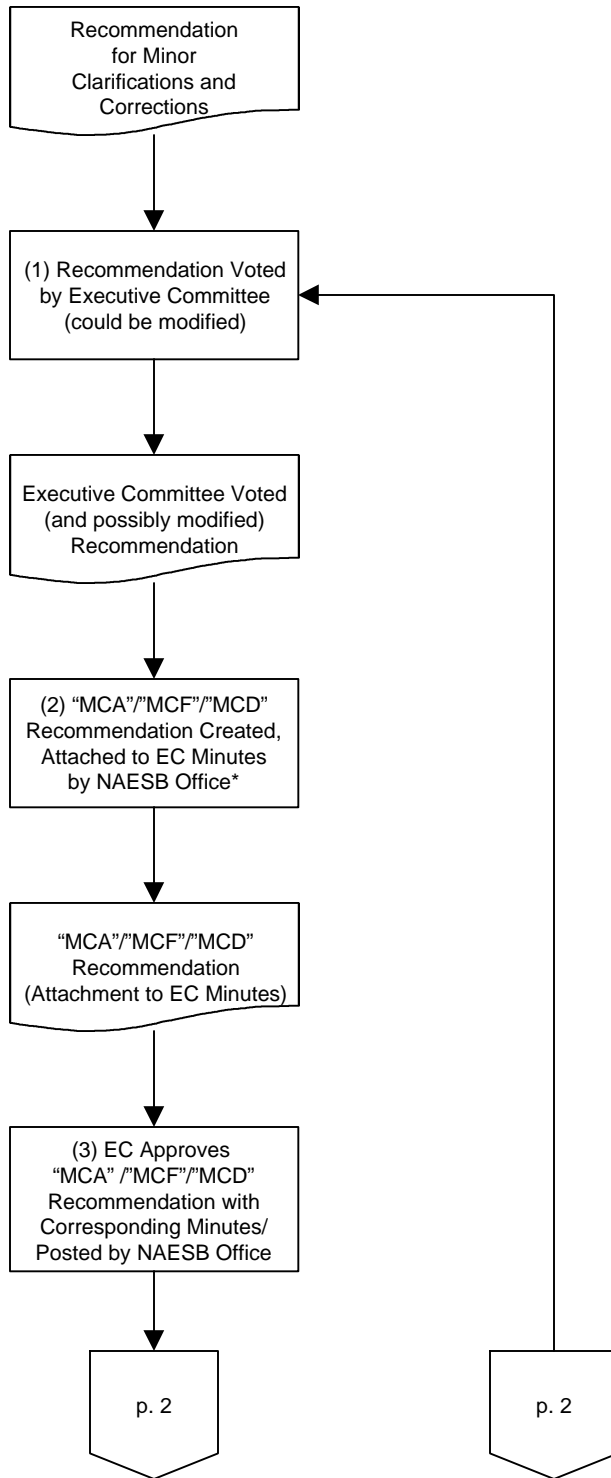

# Flow Chart of Proposed Minor Clarifications and Corrections Processing

Last Modified: 03/12/02  
Last Reviewed: 03/12/02



\*The appropriate NAESB Request Log is updated and posted to reflect this process (see Process 4 and its resulting document).

**Legend:**

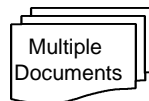
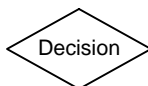
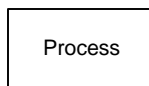
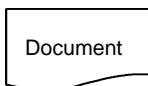

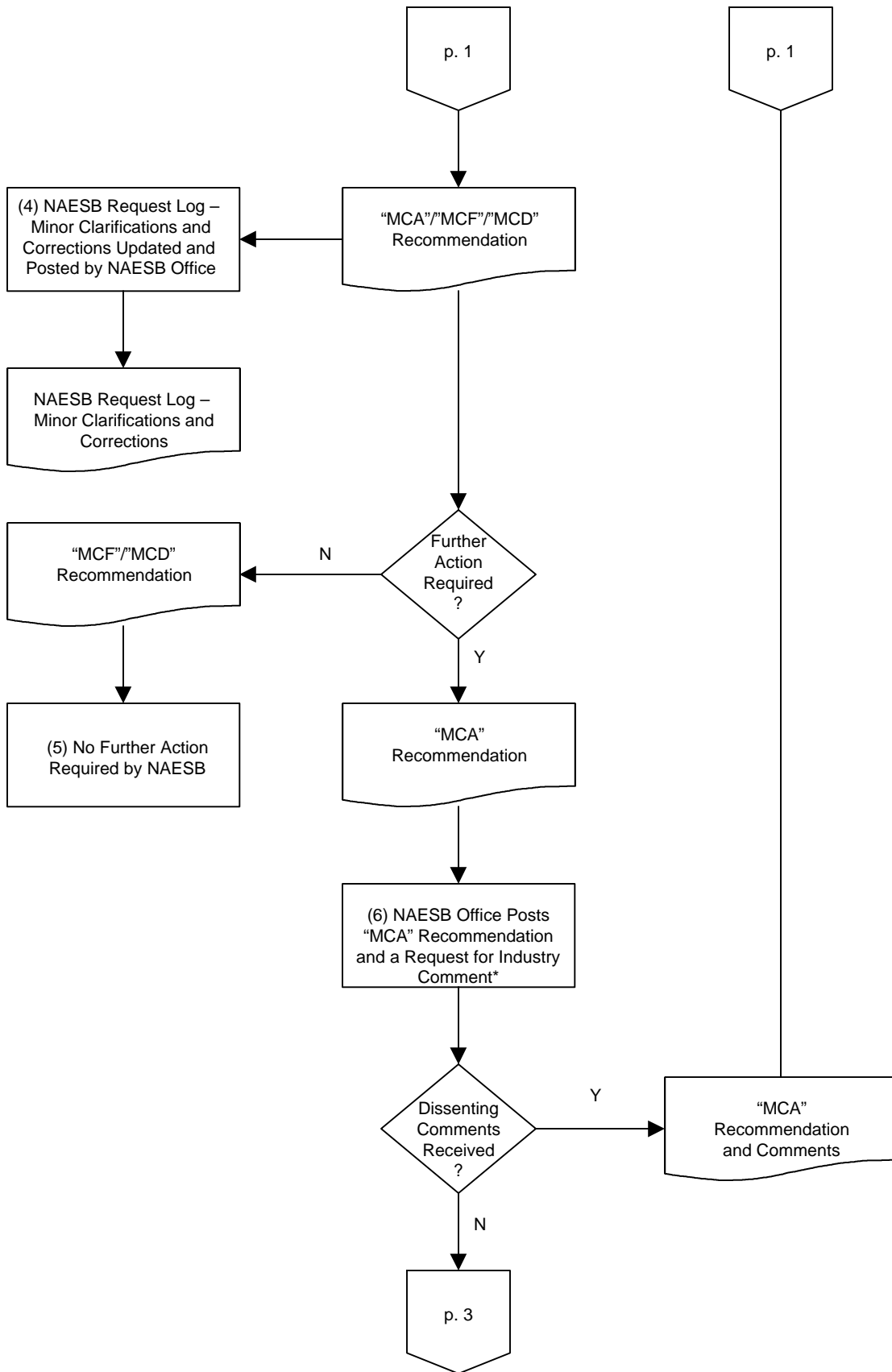

p. 2



(7) "MCAC" Recommendation Created, Added to Final Actions, and Posted by NAESB Office\*



"MCAC" Recommendation



(13) Standards Manuals Updated\*

# Flow Chart of Proposed Publication Process (Final Actions through Publication)

Last Reviewed: 03/12/02  
Last Modified: 03/12/02

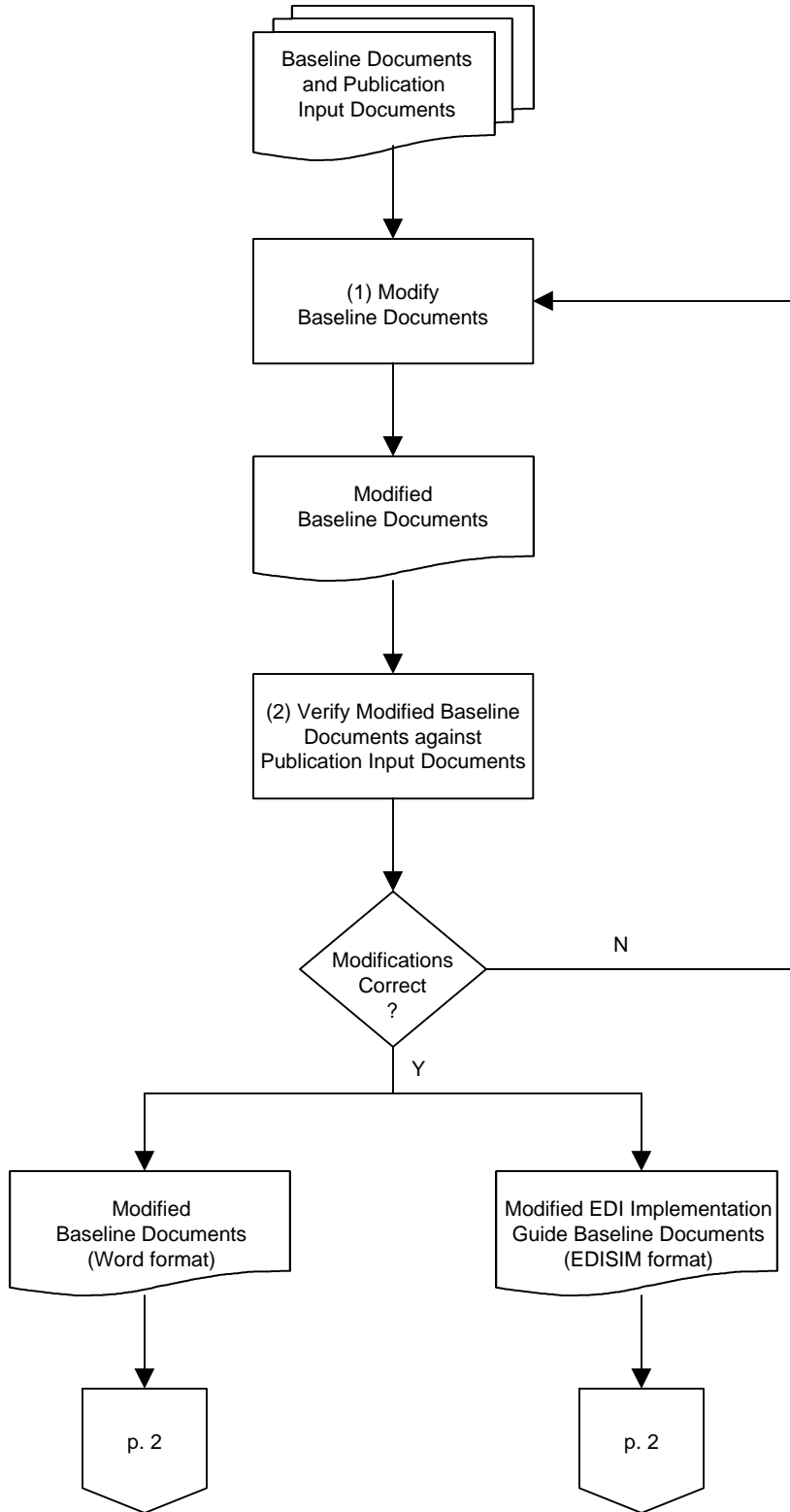

**Legend:**

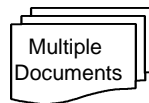
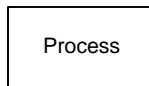
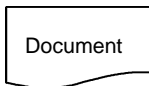

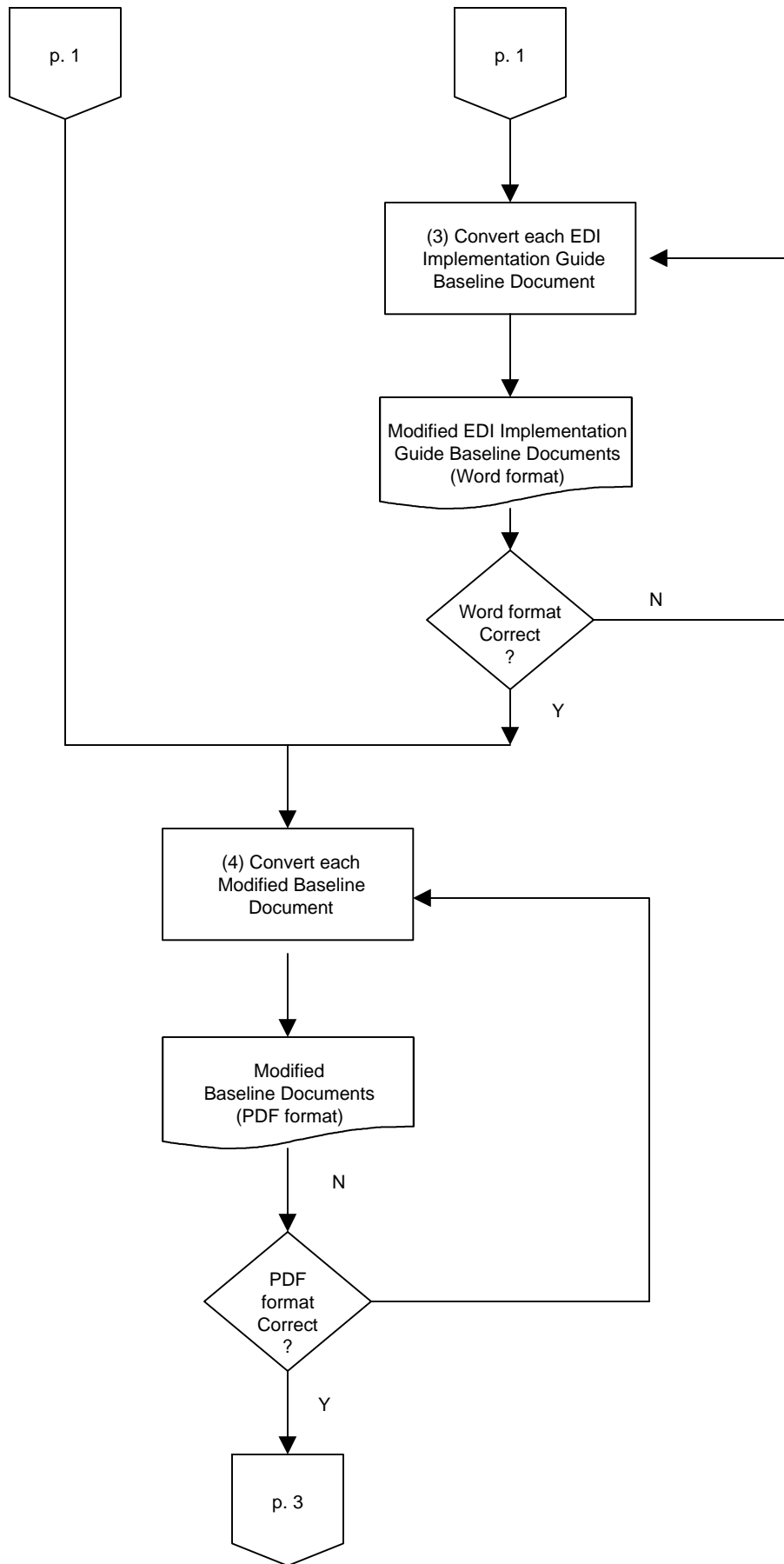

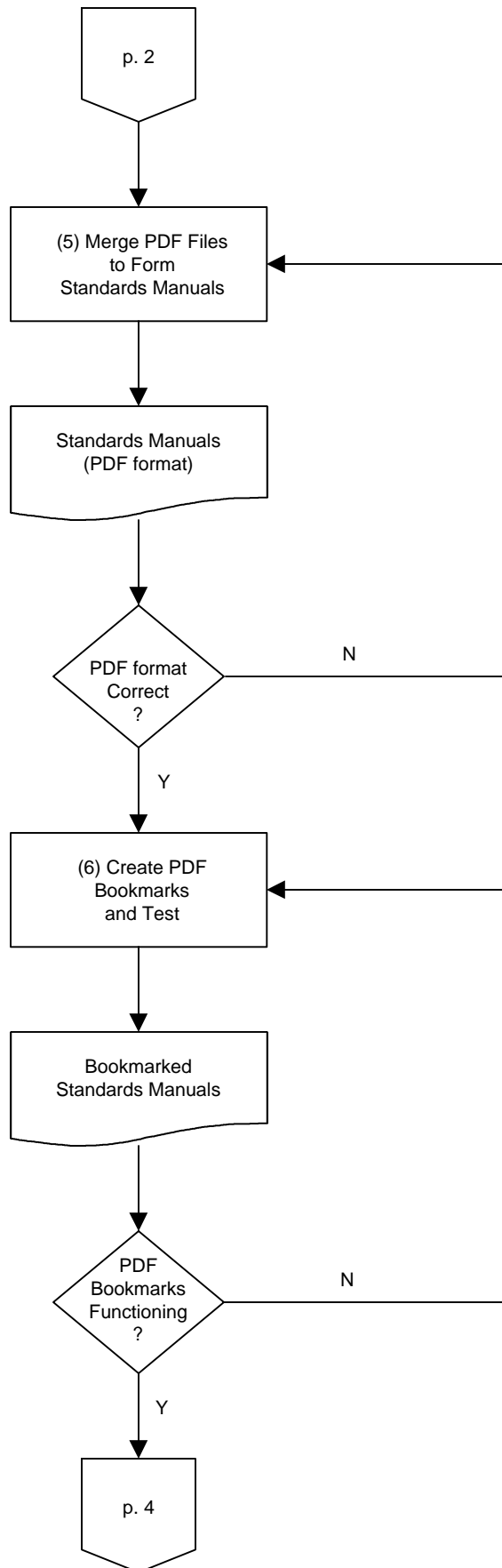

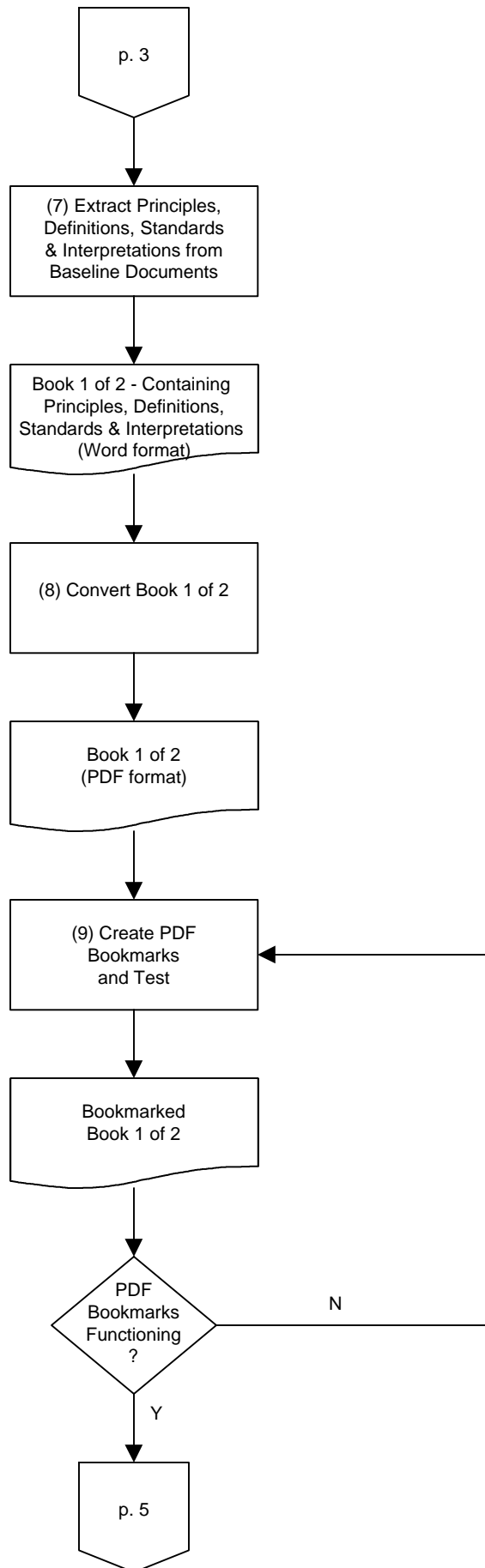

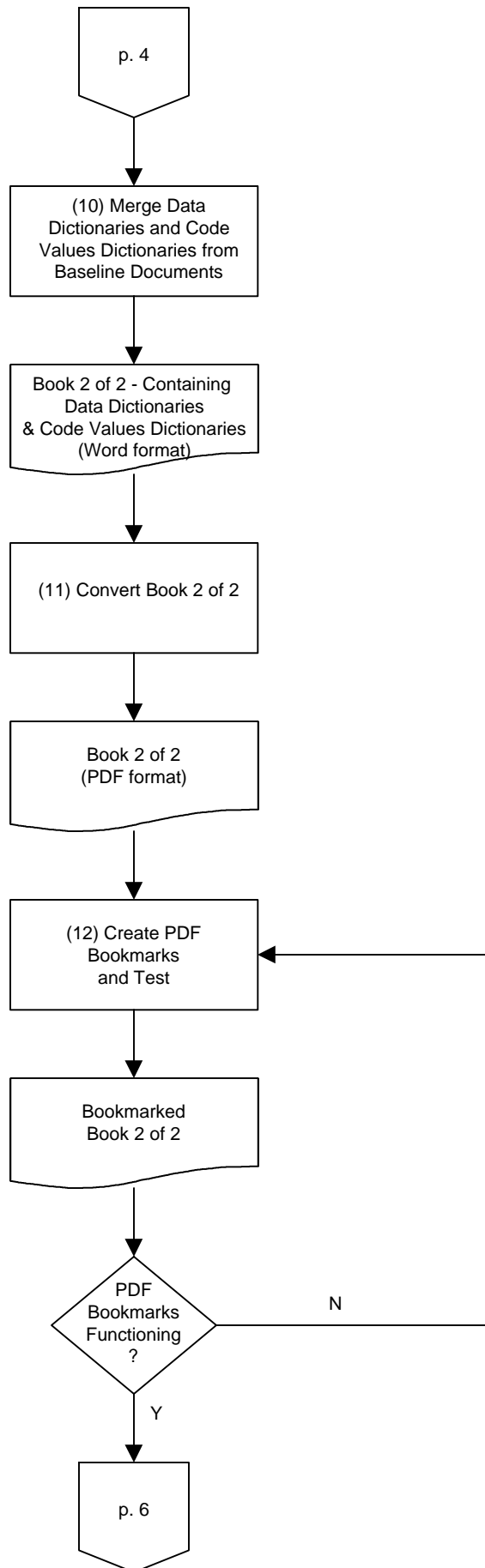

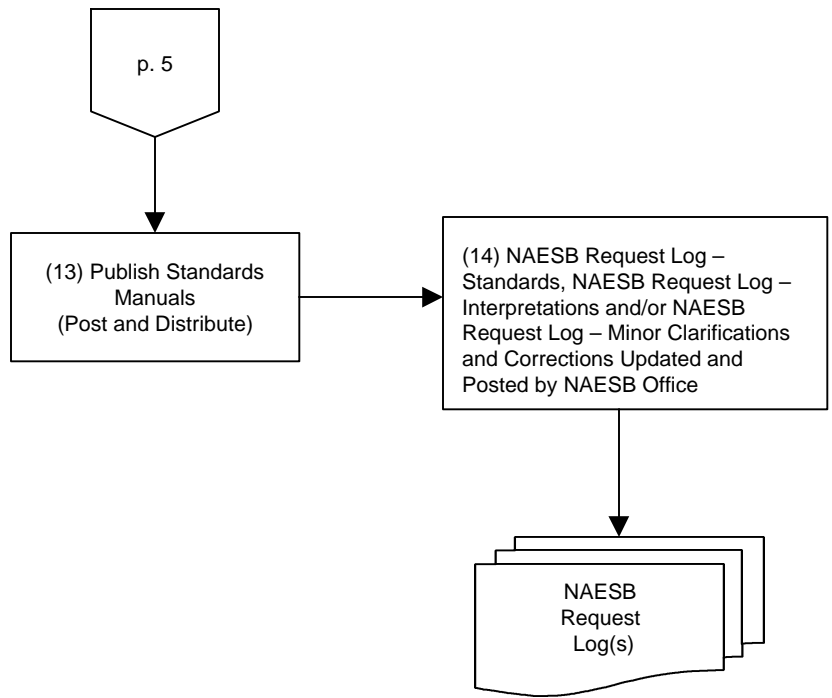

# Flow Chart of Proposed Recommendation Processing (Standards Adoption by EC through Final Actions)

Last Reviewed: 03/12/02  
Last Modified: 031202

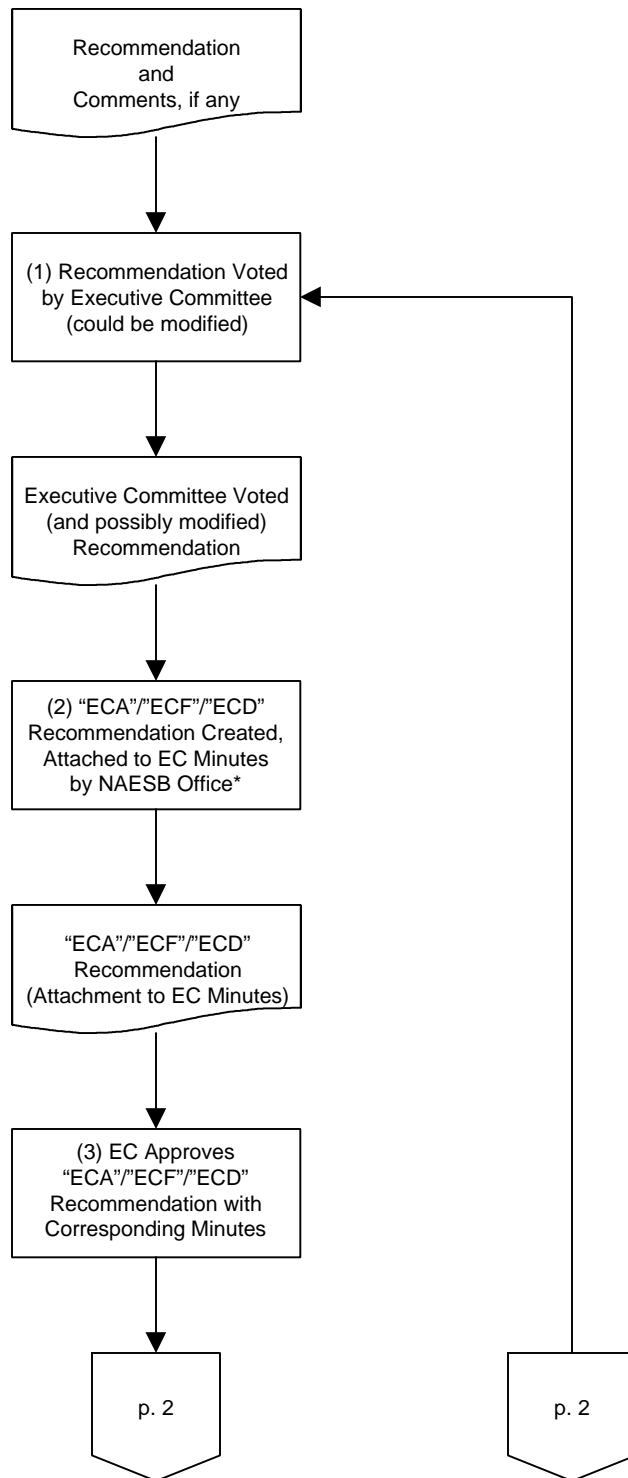

\*The appropriate NAESB Request Log(s) are updated and posted to reflect this process (see Process 4 and its resulting documents).

## Legend:

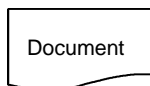

Document

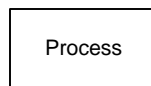

Process

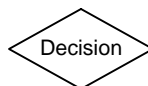

Decision

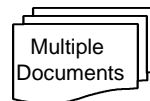

Multiple Documents

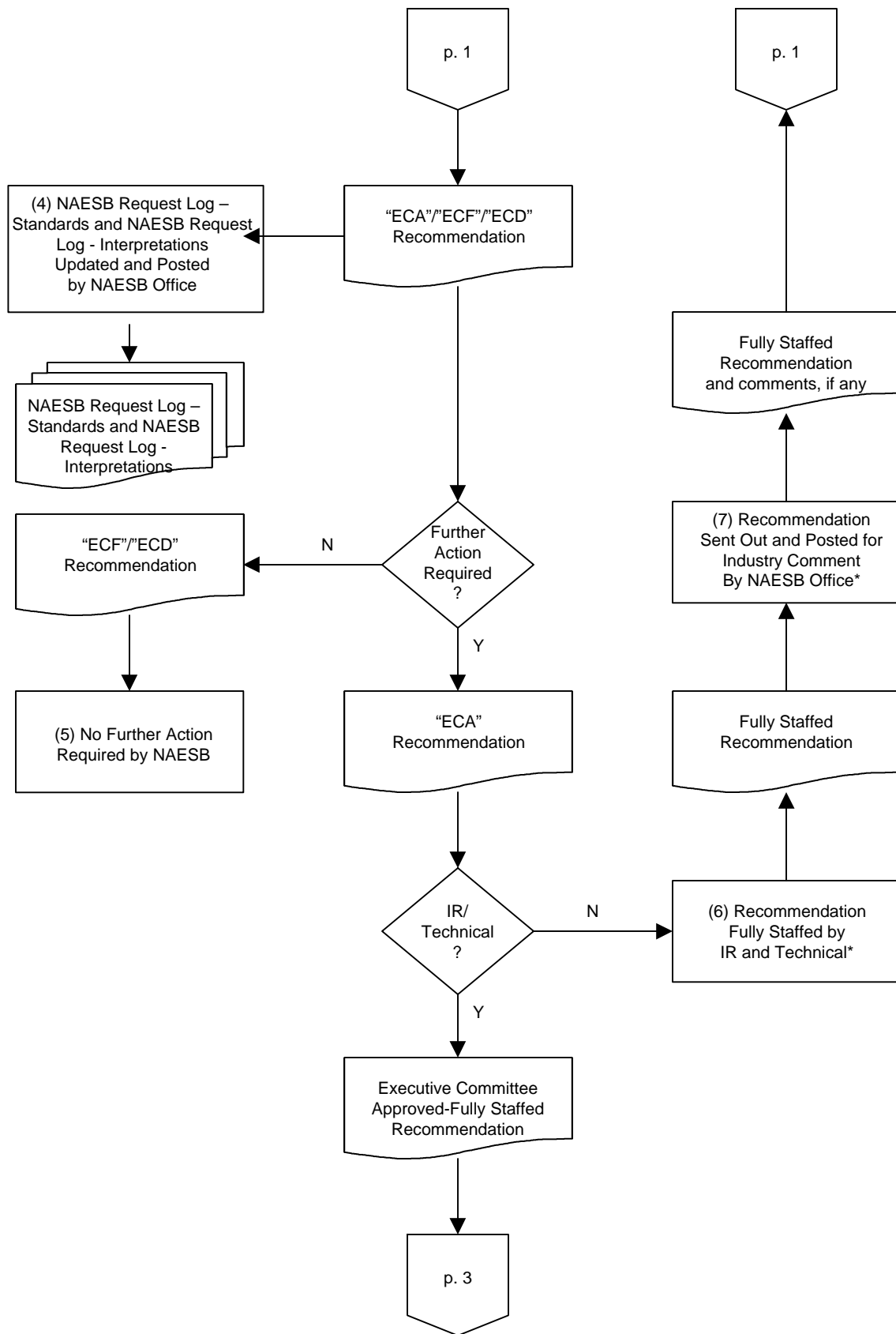

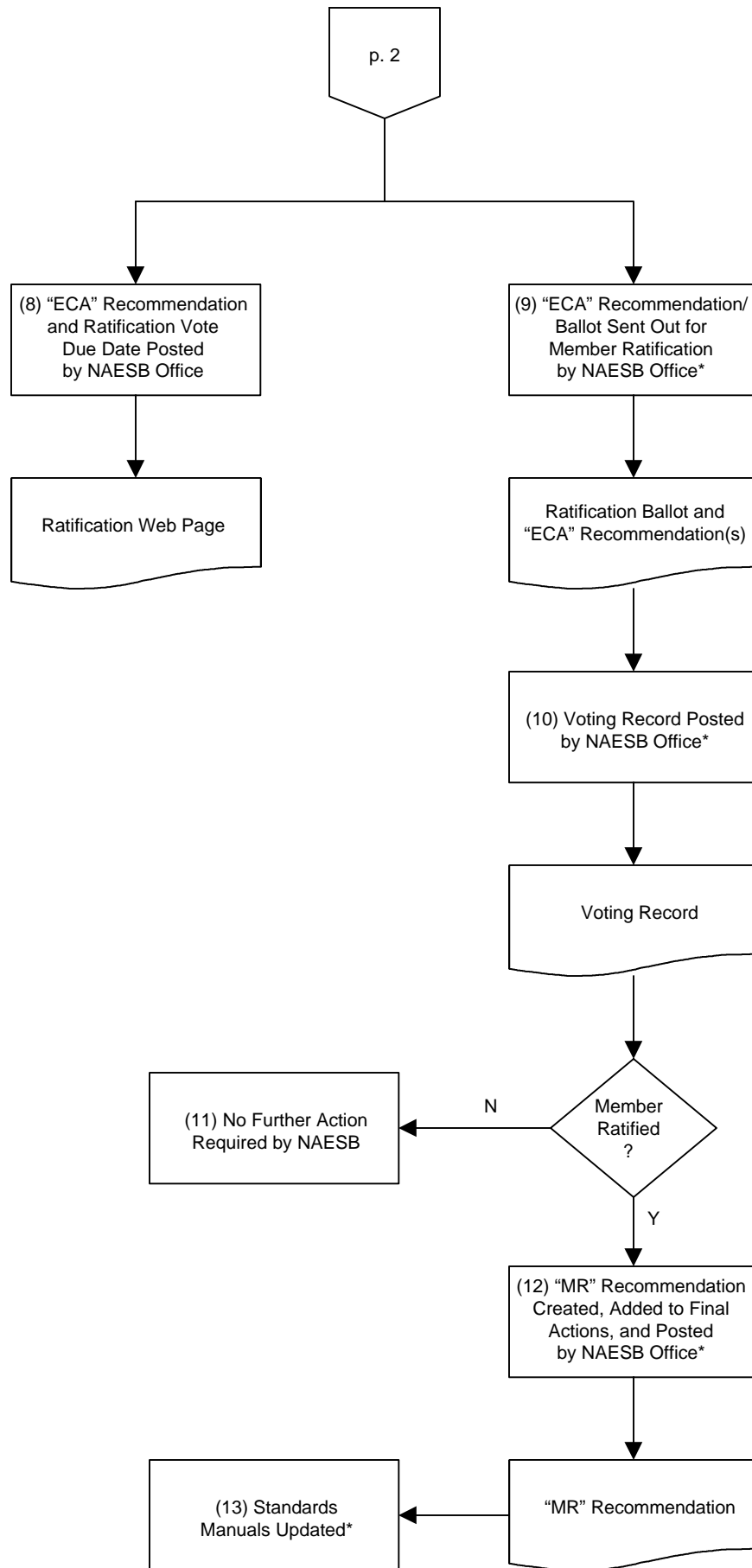

Flow Chart of Proposed Recommendation Process – p. 3

**Existing Recommendation Processing  
(Standards Adoption by EC through Final Actions)**

FINAL: 03/12/02

1. A request recommendation and its comments, if any, are presented to the Executive Committee (EC) for a vote. The EC discusses and possibly modifies the recommendation and then takes a 17/2 vote on the recommendation.
2. The Standards Request Log and/or Clarifications Log are updated to reflect the results of the EC 17/2 and procedural votes. The updated logs are posted by the NAESB Office on the NAESB Web site.
3. If the recommendation fails the EC 17/2 vote, no further action is necessary by NAESB.
4. If the recommendation passes the EC 17/2 vote, and it has not been processed by Information Requirements (IR) and Technical Subcommittees, it is sent to those subcommittees where the completion of the work (fully staffed) occurs. When completed, the chair of the Technical Subcommittee sends the fully staffed recommendation to the NAESB Office. The Standards Request and/or Clarification logs are updated and posted to reflect this process (See Process 2 and its resulting documents).
5. The NAESB Office posts the fully staffed recommendation on the NAESB Web site and sends out a request for industry comment for a period of time as specified in the GISB Operating Practices (GISBOPs). The Standards Request and/or Clarification logs are updated and posted to reflect this process (See Process 2 and its resulting documents).
6. If the EC approved-fully staffed recommendation was modified by the EC, the NAESB Office updates the recommendation and posts it, in addition to the previously posted recommendation(s) for that request, on the NAESB Web site.
7. The recommendation as approved by the EC and the corresponding ballot is sent out by the NAESB Office for member ratification for a period of time as specified in the GISBOPs. The Standards Request and/or Clarification logs are updated and posted to reflect this process (See Process 2 and its resulting documents).
8. The Membership Ratification Voting Record is posted by the NAESB Office on the NAESB Web site. The Standards Request and/or Clarification logs are updated and posted to reflect this process (See Process 2 and its resulting documents).
9. If the recommendation fails the membership ratification, no further action is necessary by NAESB.
10. If the recommendation passes the membership ratification, the NAESB Office updates the Final Actions (Standards and/or Interpretations) and posts it on the NAESB Web site. The Standards Request and/or Clarification logs are updated and posted to reflect this process (See Process 2 and its resulting documents).
11. The Final Actions (Standards and/or Interpretations) are used to update the NAESB standards manuals. The Standards Request and/or Clarification logs are updated and posted to reflect this process (See Process 2 and its resulting documents).

## **Proposed Minor Clarifications and Corrections Recommendation Processing**

Last Modified: 03/12/02  
Last Reviewed: 03/12/02

1. A Minor Clarification and Corrections Recommendation is presented to the Executive Committee (EC) for a vote. The EC discusses and possibly modifies the recommendation and then takes a procedural vote on the recommendation.
2. The NAESB Office creates a MCA/MCF/MCD Recommendation, which reflects the recommendation as approved by the EC.
  - MCA – EC approved the proposed recommendation (includes any modifications made by the EC);
  - MCF – EC did not approve the proposed recommendation; and
  - MCD – EC approved the proposed recommendation to decline the request.

The NAESB Office should create the MCA/MCF/MCD Recommendation by doing the following:

- take the recommendation and add the moniker at the end of the request number to show the EC action (MCA/MCF/MCD) and the date of the EC action. For example, if a recommendation for request M97001 is brought before the EC and approved by a procedural vote on 11/5/01, then the as approved recommendation is annotated as M97001-MCA-110501; and
- only include the contents of section 3 from the recommendation form as approved by the EC (inclusive of any modifications the EC might have made during the approval process). This should also include updating the 'Summary' section to reflect the EC's actions.

This document is posted as an attachment to the corresponding EC Minutes, both of which should be posted within seven business days of the EC meeting. The NAESB Request Log - Minor Clarifications and Corrections is updated and posted to reflect this process (see Process 4 and its resulting document).

3. By a procedural vote, as part of the EC review of the previous EC meeting minutes, the EC approves the MCA/MCF/MCD Recommendation. The MCA/MCF/MCD Recommendation is posted, in addition to the previously posted recommendation(s), on the NAESB Web site.
4. The NAESB Request Log - Minor Clarifications and Corrections is updated to reflect the results of the EC procedural vote. The updated log is posted by the NAESB Office on the NAESB Web site.
5. If it is an MCF or MCD Recommendation, no further action is necessary by NAESB.
6. The NAESB Office posts the MCA Recommendation on the NAESB Web site and posts a request for industry comment for a period of time as specified in the GISB Operating Practices (GISBOPs). The NAESB Request Log - Minor Clarifications and Corrections is updated and posted to reflect this process (see Process 4 and its resulting document).
  - If no dissenting comments are received, the MCA Recommendation is approved.
  - If dissenting comments are received, the MCA Recommendation is returned to the EC for further consideration (step 1). The NAESB Request Log - Minor Clarifications and Corrections is updated and posted to reflect this process (see Process 4 and its resulting document).

7. If the MCA Recommendation is approved, the NAESB Office updates the MCA Recommendation by modifying the moniker to reflect its completed status and the date of its completion (the Comment Due Date). Using the example in number 2 above, if M97001-MCA-110501 is subsequently completed on 02/05/02, it would be renamed M97001-MCAC-020502.

Within 7 business days of the Comment Due Date, the NAESB Office posts the MCAC Recommendation to the Final Actions and on the Request for Minor Clarifications and Corrections page on the NAESB Web site. The NAESB Request Log - Minor Clarifications and Corrections is updated and posted to reflect this process (see Process 4 and its resulting document).

8. The Final Actions are used to update the NAESB standards manuals, which should be published annually on July 31. Errata and corrections may be published as required. The NAESB Request Log - Minor Clarifications and Corrections is updated and posted to reflect this process (see Process 4 and its resulting document).

**Proposed Publication Process  
(Final Actions through Publication)**

Last Reviewed: 03/12/02

Last Modified: 03/12/02

1. Use Publication Input Documents (MR Recommendations, MCAC Recommendations, Errata, and Technical Change Log) to make modifications to the following Baseline Documents, which comprise the Standards Manuals documents:

Standards Manuals: One file contained in all Books:  
Related Standards

Standards Manuals: One file contained in Nominations, Flowing Gas, Invoicing, and Capacity Release:  
Introduction

Standards Manuals: Nominations, Flowing Gas, Invoicing, and Capacity Release: Each of the listed manuals has its own unique version of the following files:  
Table of Contents  
Version Notes  
Executive Summary  
Business Process and Practices

Standards Manuals: Nominations, Flowing Gas, Invoicing, and Capacity Release: Each data set contained within each of the listed manuals includes its own unique version of the following files:  
Technical Implementation of the Business Process  
Sample Paper Transaction  
Data Dictionary  
Data Element Cross Reference to ASC X12  
Sample ASC X12 Transaction  
EDI Implementation Guide (EDISIM)  
Transaction Set Tables

Standards Manual: Electronic Delivery Mechanism (EDM)  
Table of Contents  
Version Notes  
Introduction  
Executive Summary  
Business Process and Practices  
Technical Implementation – Internet EDI/EDM and Batch FF/EDM  
Technical Implementation – Informational Postings Web Site  
Technical Implementation – EBB/EDM  
Technical Implementation – FF/EDM  
Appendices

Standards Manual: Contracts  
Table of Contents  
Version Notes  
Introduction  
Executive Summary  
Business Process and Practices  
Standards Contracts:  
Base Contract for Sale and Purchase of Natural Gas  
Day Trade Interruptible  
Trading Partner Agreement  
Model Contracts:  
Model Funds Transfer Agreement  
Model Operational Balancing Agreement

## Sample Contracts

Summary Book 1 of 2 and Book 2 of 2  
Version Cross Reference and Interpretation Cross Reference

Summary Book 1 of 2  
Table of Contents

Summary Book 2 of 2  
Table of Contents

For each of the Baseline Documents pertaining to a given Standards Manual, changes contained in the Publication Input Documents should be made in chronological order. All files above, except the EDI Implementation Guide Baseline Documents, are updated using the Microsoft® Word product. The EDI Implementation Guide Baseline Documents are updated using FORESIGHT's® EDISIM product.

2. Verify modifications made to the Baseline Documents in step 1 above against the above listed Publication Input Documents. Also, "eyeball" formatting, such as fonts, margins, spacing, etc.
3. Each EDI Implementation Guide Baseline Document is first converted to RTF format and then imported into a Word file. This Word file is then modified to incorporate the same document formatting that is used in the rest of the Standards Manual.
4. All Word documents are converted to Adobe Acrobat PDF format. Each page is "eyeballed" for formatting issues. Note: Most formatting issues can be resolved by re-creating the PDF file.
5. The PDF files are then merged together to form the Standards Manuals. Each page is "eyeballed" for formatting issues.
6. Create PDF file Bookmarks. Proofread and test.
7. To begin creation of Summary Book 1 of 2, extract Principles, Definitions, Standards, and Interpretations from each of the modified Baseline Documents entitled Business Process and Practices created in steps 1 and 2 above (Word format) to create a single Word document. This includes merging in Table of Contents, Version Cross Reference and Interpretation Cross Reference.
8. The Word document is converted to Adobe Acrobat PDF format, creating Book 1 of 2. Each page is "eyeballed" for formatting issues. Note: Most formatting issues can be resolved by re-creating the PDF file.
9. Create PDF file Bookmarks. Proofread and test.
10. To begin creation of Summary Book 2 of 2, use Data Dictionaries and Code Values Dictionaries from each of the modified Baseline Documents created in steps 1 and 2 above (Word format) to create a single Word document containing all Data Dictionaries and Code Values Dictionaries. This includes merging in Table of Contents, Version Cross Reference and Interpretation Cross Reference.
11. The Word document is converted to Adobe Acrobat PDF format, creating Book 2 of 2. Each page is "eyeballed" for formatting issues. Note: Most formatting issues can be resolved by re-creating the PDF file.
12. Create PDF file Bookmarks. Proofread and test.
13. Publish Standards Manuals (Post and Distribute).

14. The NAESB Request Log(s) [NAESB Request Log – Standards, NAESB Request Log – Interpretations and NAESB Request Log – Minor Clarifications and Corrections] are updated to reflect the standards publication version. The updated logs are posted by the NAESB Office on the NAESB Web site.

**Proposed Recommendation Processing  
(Standards Adoption by EC through Final Actions)**

Last Reviewed: 03/12/02

Last Modified: 03/12/02

1. A request recommendation and its comments, if any, are presented to the Executive Committee (EC) for a vote. The EC discusses and possibly modifies the recommendation and then takes a 17/2 or procedural vote, as appropriate, on the recommendation.
2. The NAESB Office creates an ECA/ECF/ECD Recommendation which reflects the recommendation as approved by the EC.
  - ECA – EC approved the proposed recommendation for standards (includes any modifications made by the EC);
  - ECF – EC did not approve the proposed recommendation for standards; and
  - ECD – EC approved the proposal to decline the request.

The NAESB Office should create the ECA/ECF/ECD Recommendation by doing the following:

- Add the moniker at the end of the request number to show the EC action (ECA/ECF/ECD) and the date of the EC action. For example, if a recommendation for request R97001 is brought before the EC and approved by a 17/2 vote on 11/5/01, then the as approved recommendation is annotated as R97001-ECA-110501; and
- only include the contents of section 3 from the recommendation form as approved by the EC (inclusive of any modifications the EC may have made during the approval process). This should also include updating the 'Summary' section to reflect the EC's actions.

This document is posted as an attachment to the corresponding EC Minutes, both of which should be posted within seven business days of the EC meeting. The appropriate NAESB Request Log(s) are updated and posted to reflect this process (See Process 4 and its resulting documents).

3. By a procedural vote, as part of the EC review of the previous EC meeting minutes, the EC approves the ECA/ECF/ECD Recommendation. The ECA/ECF/ECD Recommendation is posted on the Request for Standards or Clarification Request Page, as appropriate, in addition to the previously posted recommendation(s), on the NAESB Web site.
4. The NAESB Request Log – Standards and / or the NAESB Request Log – Interpretations are updated to reflect the results of the EC 17/2 and procedural votes. The updated logs are posted by the NAESB Office on the NAESB Web site.
5. For an ECF or ECD Recommendation, no further action is necessary by NAESB.
6. For an ECA Recommendation that has not been processed by Information Requirements (IR) and Technical Subcommittees, it is sent to those subcommittees where the completion of the work (fully staffed) occurs. The appropriate NAESB Request Log(s) are updated and posted to reflect this process (See Process 4 and its resulting documents).

When completed, the chair of the Technical Subcommittee sends the fully staffed recommendation to the NAESB Office no later than 12:00 p.m. (Central Clock Time) on the business day before the industry comment period is scheduled to begin.

7. The NAESB Office posts the fully staffed recommendation, in addition to the previously posted recommendation(s) on the Request for Standards or Clarification Request Page, as appropriate, on the NAESB Web site. The NAESB Office sends out a request for industry comment for a period of time as specified in the GISB Operating Practices (GISBOPs). The appropriate NAESB

Request Log(s) are updated and posted to reflect this process (See Process 4 and its resulting documents).

8. The NAESB Office posts the ballot due date and the corresponding ECA Recommendation(s) on the NAESB Web site Ratification Page. The ratification due date is also reflected on the NAESB Calendar that is posted on the NAESB Web site.
9. The Member Ratification ballot and the corresponding ECA Recommendation(s) are sent out by the NAESB Office for member ratification within five business days of the approval of the ECA Recommendation for a period of time as specified in the GISBOPs. The appropriate NAESB Request Log(s) are updated and posted to reflect this process (See Process 4 and its resulting documents).
10. The Membership Ratification Voting Record is posted by the NAESB Office on the NAESB Web site within 3 business days of the ratification due date. The appropriate NAESB Request Log(s) are updated and posted to reflect this process (See Process 4 and its resulting documents).
11. If the ECA Recommendation fails the membership ratification, no further action is necessary by NAESB.
12. If the ECA Recommendation passes the membership ratification, the NAESB Office updates the ECA Recommendation by doing the following:
  - modify the moniker to reflect its ratified status and the date of the ratification. Using the example in #2 above, if R97001-ECA-110501 is subsequently member ratified on 1/15/02, it would then be referred to as R97001-MR-011502; and
  - incorporate, if appropriate, the new NAESB standard numbers.

Within 7 business days of the ratification due date, the NAESB Office posts the MR Recommendation to the Final Actions and on the Request for Standards or Clarification Request Page, as appropriate, on the NAESB Web site.

13. The Final Actions are used to update the NAESB standards manuals which should be published annually on July 31. Errata and corrections may be published as required. The appropriate NAESB Request Log(s) are updated and posted to reflect this process (See Process 4 and its resulting documents).

**PROPOSED TIMELINE TABLE FOR PUBLICATION OF NAESB STANDARDS**

Last Modified: 03/12/02

Last Reviewed: 03/12/02

Step	Duration	Cumulative Days	Event	Notes
1	1	1	Last EC Approved Recommendation Voted	This is the last date an EC meeting can be held during which a vote on fully staffed recommendations (standards and clarifications) that effect the next version.
2	10	11	EC Minutes prepared and adopted	This is the last date an EC meeting can be held to adopt minutes from the EC meeting in Step 1. It may be held by conference call.
3	23 <sup>1</sup>	34	Member Ratification	Can be shortened by EC if necessary. A 30-calendar day ratification period incorporates 20 working days.
4	30	44	Changes made to baseline <sup>2</sup> documents and proofing	This step begins after completion of Step 2. If Step 3 (ratification) fails changes are omitted. This is an iterative process which may involve "volunteers" and others knowledgeable about specific content revisions. It includes proofing of content and format.
5	3	47	Prepare Standards Manuals in PDF format containing the documents from Step 4	This includes the compilation and bookmarking of the Standards Manuals.
6	2	49	Prepare Book 1 of 2 and Book 2 of 2 in PDF format containing the documents from Step 4	This includes the compilation and bookmarking of Book 1 of 2 and Book 2 of 2 (Summary Books).
7	3	52	Final Proofing	No content proofing takes place; this is a review of the print layout and is the last review of media preparation input materials.
8	3 <sup>3</sup>	55  July 31	Publication Date	Revised Standards Manuals and Summary Books are available to members via PDF files posted on the NAESB Web site. It is the recommendation of the PPRTF that preparation of the printed materials and CDs be a post-publication process.

General Notes:

- Date refers to a duration of time with the exception of Step 8, which is a deadline. Each step presumes completion of the previous step, except where noted.
- All days, unless otherwise noted, are business/working days.
- Within each step above, specific timelines may be established for coordination of work.

Footnotes:

1. Assumes 3 days to prepare document for member ratification.
2. Baseline documents consist of the following

Standards Manuals: One file contained in all Books:  
Related Standards

Standards Manuals: One file contained in Nominations, Flowing Gas,  
Invoicing, and Capacity Release:  
Introduction

Standards Manuals: Nominations, Flowing Gas, Invoicing, and  
Capacity Release: Each of the listed manuals has its own  
unique version of the following files:  
Table of Contents  
Version Notes  
Executive Summary  
Business Process and Practices

Standards Manuals: Nominations, Flowing Gas, Invoicing, and  
Capacity Release: Each data set contained within each of the  
listed manuals includes its own unique version of the following  
files:  
Technical Implementation of the Business Process  
Sample Paper Transaction  
Data Dictionary  
Code Values Dictionary  
Data Element Cross Reference to ASC X12  
Sample ASC X12 Transaction  
EDI Implementation Guide (EDISM)  
Transaction Set Tables

Standards Manual: Electronic Delivery Mechanism (EDM)  
Table of Contents  
Version Notes  
Introduction  
Executive Summary

Business Process and Practices  
Technical Implementation – Internet EDI/EDM and Batch  
FF/EDM  
Technical Implementation – Informational Postings Web Site  
Technical Implementation – EBB/EDM  
Technical Implementation – FF/EDM  
Appendices

Standards Manual: Contracts  
Table of Contents  
Version Notes  
Introduction  
Executive Summary  
Business Process and Practices  
Standard Contracts:  
Base Contract for Sale and Purchase of Natural Gas  
Day Trade Interruptible  
Trading Partner Agreement  
Model Contracts:  
Model Funds Transfer Agreement  
Model Operational Balancing Agreement  
Sample Contracts

Summary Book 1 of 2 and Book 2 of 2  
Version Cross Reference and Interpretation Cross  
Reference

Summary Book 1 of 2  
Table of Contents

Summary Book 2 of 2  
Table of Contents

3. If preparation of the printed materials and CDs is a pre-publication process, an additional step with a duration of 20 days will increase the number of cumulative days since the beginning of the publication process to 92 days. The preparation of the printed materials and CDs is an iterative exchange of materials between the NAESB office and the publication vendor(s) for quality control purposes.

# Flow Chart of Existing Recommendation Processing (Standards Adoption by EC through Final Actions )

FINAL: 03/12/02

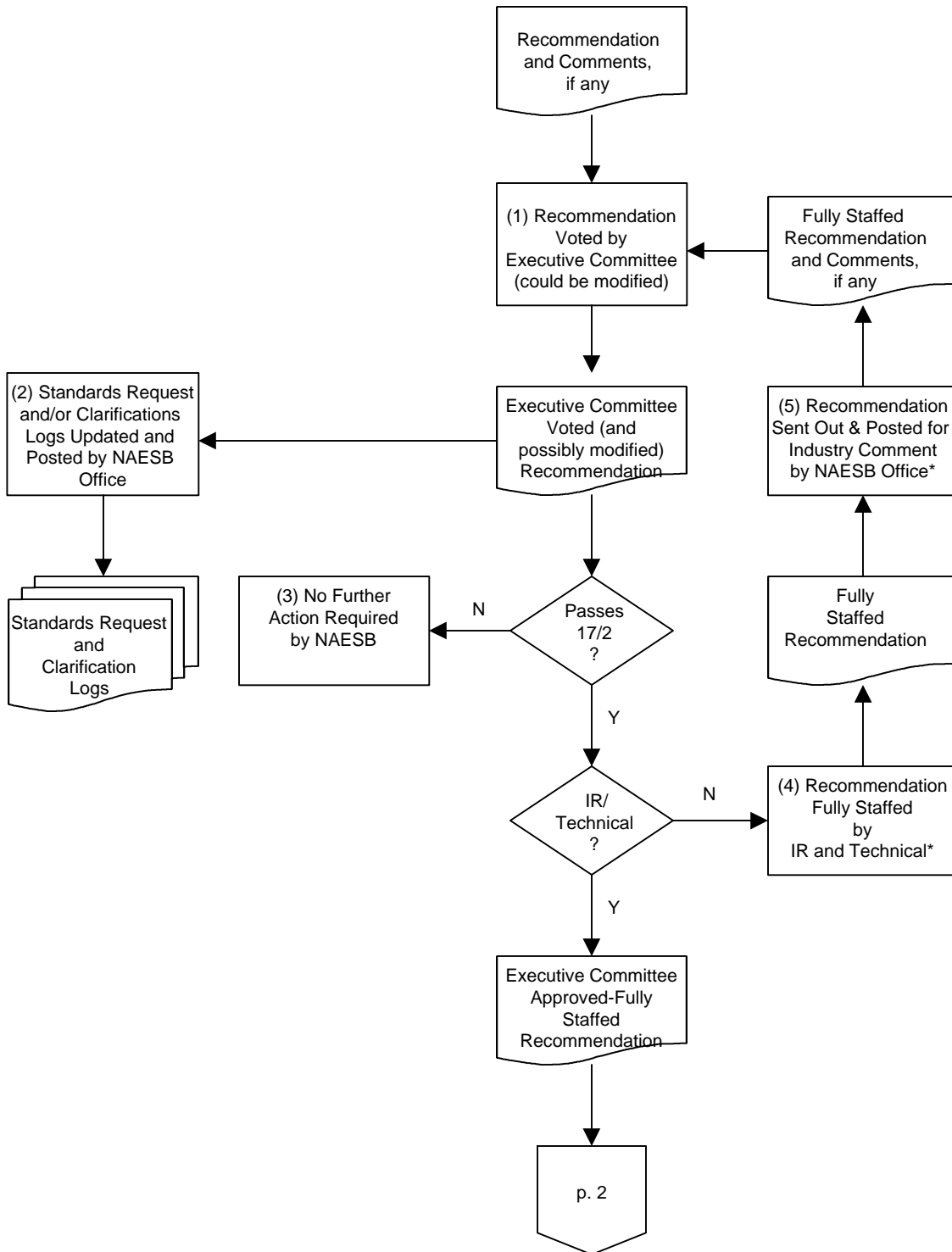

\*The standards and/or clarification logs are updated and posted to reflect this process (see Process 2 and its resulting documents).

**Legend:**

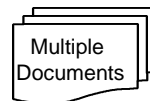
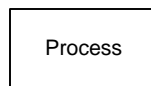
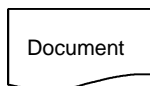

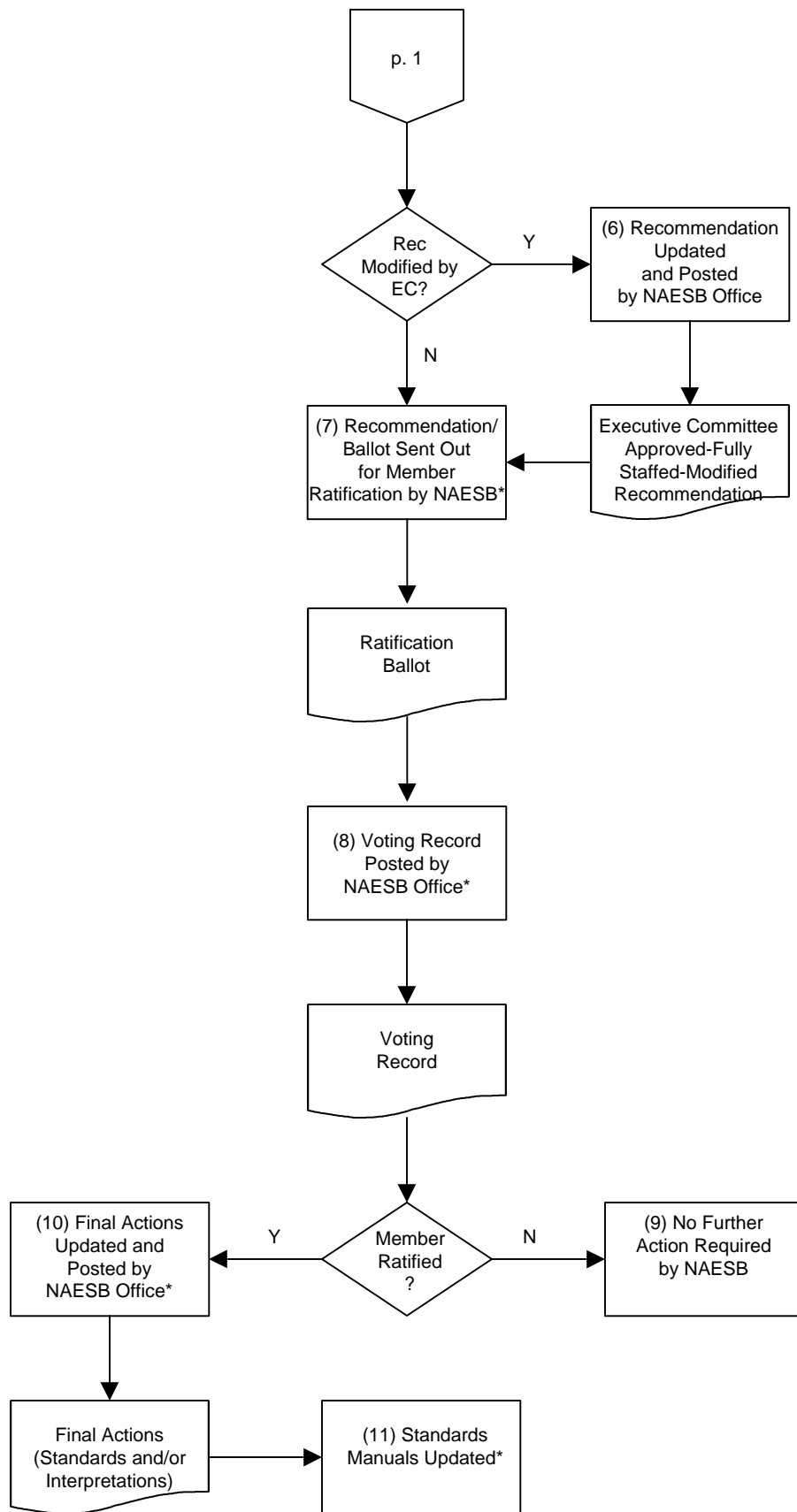

## NAESB REQUEST LOG - STANDARDS – YYYY

CURRENT AS OF (DATE)

[Note for explanation purposes: **Blue indicates links** **Red indicates there is a legend below** **Green shows a hypothetically completed request**]

REQUEST INFORMATION			STATUS	REQUEST PROCESSING		EC PROCESSING			FINAL PROCESSING		
REQUEST NO.	DESCRIPTION	REQUESTER & DATE REC'D	SC / TF (GROUP)	PRIORITY	GROUP & MEETING DATE	COMMENT DUE DATE	EC ACTION DATE	EC ACTION	RATIFICATION BALLOT DUE / RESULTS	FINAL ACTION POSTED	STANDARD New (N) / Modified (M)
(1)	(2)	(3)	(4)	(5)	(6)	(7)	(8)	(9)	(10)	(11)	(12)
( <a href="#">Link to the request</a> ) R01001					( <a href="#">Link to minutes for each of the meeting dates shown</a> )	( <a href="#">Link to request for comment</a> )	( <a href="#">Link to minutes for the date</a> )		( <a href="#">link to ballot</a> ) / ( <a href="#">link to voting results</a> )	( <a href="#">link to Final Actions posted</a> )	
R01001	Add Change Gas Transaction Points Terms data element to various Capacity Release data sets.	Enron (ETS) 1/24/01	7-VER 1.7	NB	TR 2/13/01 EC 2/22/01 BPS 3/15/01 BPS 3/29/01 IR 1/15/02 IR 2/12/02 TECH 2/21/02 EC 4/11/02 IR 5/14/02 TECH 6/4/02 EC 8/15/02 EC 10/10/02	4/02/02  8/05/02	2/22/01  4/11/02  8/15/02 8/31/02 10/10/02	IN XFER-BPS  XFER-IR  ONV PASS MIN-PASS	Ballot: 11/30/02  Results: PASS	12/15/02	5.3.200 (N) 5.4.55 (M) 5.4.56 (M) 5.4.62 (M)
R98031	Develop an EDI data set to allow Confirmation Parties to elect to "Confirm by Exception" as provided for in 1.2.11 and 1.3.22. This would be classified as a "new transaction."	Tennessee 10/6/98	9 - NFA	NB	EC 10/15/98 EIITF 11/04/98 IR 01/11/00 BPS 02/24/00 EC 06/15/00	5/30/00	10/15/98  06/15/00	IN XFER-EIITF  DECLINE	N/A	N/A	N/A
R01014	Add Payee Bank Name, Payee Bank Location and Payee Bank Reference Information data elements to both Invoices.	Williams 3/21/01	2-IR (INV)	CUR	TR 4/11/01 EC 4/19/01 BPS 5/24/01 BPS 7/12/01 IR		4/19/01	IN XFER-BPS			
R01015	Add Reduction Reason code values to the Confirmation Response, Scheduled Quantity and Scheduled Quantity for Operator.	Enron (ETS) 5/10/01	8-W/D	NB	TR 6/8/01 EC 6/14/01 BPS 6/21/01		6/14/01	IN XFER-BPS	N/A	N/A	N/A

## NAESB REQUEST LOG – INTERPRETATIONS – YYYY

CURRENT AS OF (DATE)

[Note for explanation purposes: **Blue indicates links** **Red indicates there is a legend below** **Green shows a hypothetically completed request**]

REQUEST INFORMATION		REQUESTER & DATE REC'D	STATUS	REQUEST PROCESSING		EC PROCESSING			FINAL PROCESSING		
REQUEST NO.	DESCRIPTION		SC / TF (GROUP)	PRIORITY	GROUP & MEETING DATE	COMMENT DUE DATE	EC ACTION DATE	EC ACTION	RATIFICATION BALLOT DUE / RESULTS	FINAL ACTION POSTED	STANDARD New (N) / Modified (M)
(1)	(2)	(3)	(4)	(5)	(6)	(7)	(8)	(9)	(10)	(11)	(12)
<a href="#">(Link to the request)</a>					<a href="#">(Link to minutes for each of the meeting dates shown)</a>	<a href="#">(Link to request for comment)</a>	<a href="#">(Link to minutes for the date)</a>		<a href="#">(link to ballot) /</a> <a href="#">(link to voting results)</a>	<a href="#">(link to Final Actions posted)</a>	
C00001	Calculation of Fuel for Pathed Non-threaded - should it be based on gross receipts or delivered volumes?	Hatch 1/05/01	7-VER 1.5	NB	IS 2/4/00 IS 5/26/00 EC 8/24/00 EC 10/24/00	8/04/00	8/24/00 10/24/00	PASS MIN-PASS	Ballot: 11/20/00  Results: PASS	2/25/01	7.3.85 (N)

## NAESB REQUEST LOG - MINOR CLARIFICATIONS AND CORRECTIONS – YYYY

CURRENT AS OF (DATE)

[Note for explanation purposes: **Blue indicates links** **Red indicates there is a legend below** **Green shows a hypothetically completed request**]

REQUEST INFORMATION			STATUS	REQUEST PROCESSING		EC PROCESSING			FINAL PROCESSING		
REQUEST NO.	DESCRIPTION	REQUESTER & DATE REC'D	SC / TF (GROUP)	PRIORITY	GROUP & MEETING DATE	COMMENT DUE DATE	EC ACTION DATE	EC ACTION	RATIFICATION BALLOT DUE / RESULTS	FINAL ACTION POSTED	STANDARD New (N) / Modified (M)
(1)	(2)	(3)	(4)	(5)	(6)	(7)	(8)	(9)	(10)	(11)	(12)
<a href="#">(Link to the request)</a>					<a href="#">(Link to minutes for each of the meeting dates shown)</a>	<a href="#">(Link to request for comment)</a>	<a href="#">(Link to minutes for the date)</a>		<a href="#">(link to ballot) /</a> <a href="#">(link to voting results)</a>	<a href="#">(link to Final Actions posted)</a>	
M02005	In Standard 3.4.87, for the data element Charge Type, the code value 'Capacity Constraint 'Crede' should be 'Capacity Constraint Credit'.	XYZ Pipeline	7-VER 1.7	NB	EC 9/14/02 EC 11/14/02	12/14/02	9/14/02 11/14/02	PASS MIN-PASS	N/A	12/21/02	3.4.87 (M)

## LEGENDS

### STATUS – SUBCOMMITTEE TASK FORCE (GROUP)

#### STATUS

1 - SC / TF (GROUP) Subcommittee or Task Force from the following lists:

Example: BPS (CR)

#### SUBCOMMITTEE / TASK FORCE

ACT	ANSI Compliance Team
APSC	Annual Plan Subcommittee
BPS	Business Practices Subcommittee
CCSC	Common Codes Subcommittee
CSC	Contracts Subcommittee
EIITF	EBB - Internet Implementation Task Force
EC	Executive Committee
FTTF	Future Technology Task Force
PSC	Process Subcommittee
IR	Information Requirements Subcommittee
ISC	Imbalance Subcommittee
IS	Interpretation Subcommittee
TECH	Technical Subcommittee (was Task Force)
TR	Triage
XML	XML Subcommittee (under EDM Subcommittee)

#### (GROUP)

(CR)	Capacity Release related
(EDM)	Electronic Delivery Mechanism related
(FG)	Flowing Gas related
(GEN)	General
(INV)	Invoicing related
(K)	Contracts related
(NOM)	Nomination related
(O637)	Order 637

2-OIC	Out for Industry Comment
3-ECAopt	EC Adopted / Pending 'ECA' / 'MCA' Recommendation Procedural Approval
4-ECA Rec	'ECA' Recommendation Procedurally Approved / Pending Member Ratification
5-MR	Member Ratified / Pending Publication
6-MCAC	Completed Minor Clarifications and Corrections / Pending Publication
7-VER X.X	Publication Version
8-W/D	Withdrawn
9-NFA	No further action

#### PRIORITY

(Note: can be more than one – Example: Cur – hi = address it in the current round of business and make it the highest priority with those items in the round)

CUR	Current Round of Business (include it in the Group currently being addressed)
NB	Normal Course of Business
HI	High priority
LO	Low Priority

#### EC ACTION:

DECLINE	Affirmative Procedural Vote to Decline Request
FAIL	Failed the 17/2 Vote of the EC
IN	In Scope
MIN-PASS	'ECA'/'MCA' Attachment to EC Minutes Approved
ONV	Out for Notational Vote
OPV-FAIL	Other Procedural Vote Failed
OPV-PASS	Other Procedural Vote Passed
OUT	Out of Scope
PASS	Passed the 17/2 vote of the EC
POSTPN	Postponed for later consideration
TABLE	Item tabled by the EC
XFER	Transfer to Subcommittee (include Subcommittee or Task Force)

# Proposed NAESB Request Logs

Last Reviewed: 03/12/02

Last Modified: 03/12/02

**Column 1: Request No.**

The request number assigned by the NAESB office. There is a link from each request number to the corresponding actual request posted on the appropriate page as follows:

- Requests for Standards
- Clarification Requests or
- Minor Clarifications and Corrections.

**Column 2: Description**

Brief description of the request.

**Column 3: Requester & Date Rec'd**

The name of the party submitting the request and the date it was received by the NAESB office.

**Column 4: SC/TF (Group)**

This column provides several pieces of information.

- The status is a numerical code representing the location of the request in the NAESB process.
- SC/TF – indicates the subcommittee or task force where the request currently resides.
- (Group) – the category / topic of the request. This information is deleted when the recommendation is available for industry comment.

Refer to legend for the complete listing of code values for each of these items.

**Column 5: Priority**

The priority assigned to the request by the Executive Committee. Refer to legend for the complete listing of code values for this item.

**Column 6: Group and Meeting Date**

For all of the SC/TF (Group) meetings where the item is discussed, the name of the group and the date of each meeting. This includes all EC meetings. This is a comprehensive list that is updated throughout the processing of the request so that users have the ability to see the historical path of the request. Each date is a link to the corresponding meeting minutes posted on the NAESB Web site.

Anytime the EC meets and discusses a request, the dates and actions will be further delineated in columns 8 and 9.

**Column 7: Comment Due Date**

The date when comments are due to the NAESB office. The date is a link to the corresponding request for comments posted on the NAESB Web site. For Standards or Interpretations, the comment due date is prior to the EC meeting where the corresponding recommendation is acted upon. For Minor Clarifications and Corrections, the comment due date is after the EC has approved the recommendation.

**Column 8: EC Action Date**

The date on which the EC took any and all actions on the request, not limited to a 17/2 vote. Each date is a link to the corresponding meeting minutes posted on the NAESB Web site.

**Column 9: EC Action**

All EC actions are recorded. This is a comprehensive list that is updated throughout the processing of the request so that users have the ability to see the historical path of the request. Refer to legend for the complete listing of code values for this item.

**Column 10: Ratification Ballot Due / Results**

The date when member ratification ballots are due to the NAESB office. The date is a link to the corresponding ratification ballot on the NAESB Web site. The indicated results of the vote are a link to the voting record posted on the NAESB Web site. Minor Clarifications and Corrections are not subject to member ratification.

**Column 11: Final Action Posted**

The date when the MR / MCAC Recommendation is posted to the Final Actions on the NAESB Web site. The date is a link to such MR / MCAC Recommendation.

**Column 12: Standard New (N) / Modified (M)**

The number of the new or modified standard(s) or clarification(s) contained in the MR / MCAC Recommendation.