



# Gas Industry Standards Board

1100 LOUISIANA, SUITE 4925, HOUSTON, TEXAS, 77002  
PHONE - (713) 757-4175, FAX - (713) 757-2491, email gisb@aol.com  
HOME PAGE www.gisb.org

May 22, 1998

**TO:** GISB Membership and posting on the home page for interested industry participants  
**FROM:** Rae McQuade, Executive Director  
**RE:** **FINAL MINUTES FOR IMBALANCE SUBCOMMITTEE MAY 22, 1998 MEETING**

## **I. Administrative**

Ms. McQuade gave the roll call. Mr. Buccigross welcomed the attendees to the Imbalance Subcommittee call and gave the antitrust advice. The agenda was adopted as written with the change to adopt the May 6 minutes. The minutes of May 6 were revised and adopted as final.

## **II. Issues -- Request No. R97117, R97118**

### **Work paper submitted for discussion:**

Imbalances Subcommittee Issues List Resulting from the May 6, 1998 Conference Call  
Authorization/Posting/Request-Response Process:

#### Authorization Issues:

1. Authorization by specific area or zone
2. Authorization by specified contracts
3. Authorization by specified rate schedule
4. Authorization by/for specified date ranges
5. Daily/monthly issues
6. Timing Issues
7. Operational Impact Areas
8. Overwrite/Change authorization issues

#### Posting Issues:

1. Posting by specific area or zone, specified contracts, *et al.*
2. Daily/monthly issues
3. Timing issues
4. Nomination process issues (per proposed standard No. 1.3.X)
5. Administration
6. Concurrency of trades
7. Operational Impact Areas
8. Total/changes only posting
9. Zero Imbalance posting question
10. OBA Imbalance posting question

### **Discussion -- Authorization:**

For authorization of imbalance trading postings, there was discussion on the need for authorization by operational impact area or rate zone (issue nos. 1 and 7). Posting all imbalances or imbalances by operational impact area may work, but concern was raised on posting by zone, because zones could cross operational areas. If zones are used, then operational areas should also be identified, but the recommendation was made not to post by zone due to a more complicated process and opportunity for error. Operational impact areas may or may not be static depending on each pipeline, their operational impact areas at the time, and capacity constraints in effect at a particular time. It is unlikely that operational impact areas would change very often. The pipelines on the call did not indicate concern with the use of operational impact areas ("op areas").

Enron recommended that imbalance types be used as an option for posting. They have five types. Imbalances are defined on FGT's system as actual quantities versus scheduled quantities, with the types based geographically, on receipt side and on delivery side (western, market, no notice and



# Gas Industry Standards Board

1100 LOUISIANA, SUITE 4925, HOUSTON, TEXAS, 77002  
PHONE - (713) 757-4175, FAX - (713) 757-2491, email gisb@aol.com  
HOME PAGE www.gisb.org

small cities). An imbalance type data element with code values to reflect the types described above would support the business practices. There may also need to be a function to indicate no authorization required as some pipelines post all imbalances without prior authorization. Imbalance types may be independent of operational impact areas.

Authorization and posting by contract was determined to be needed. Legal entity, rate schedule and contract should all be supported for both authorization and posting. Operational impact area can be either independent or another level of authorization or posting within legal entity, rate schedule or contract.

Posting or imbalances for trading or netting by percentage or by a specific quantity should be accommodated. Imbalance statement should be reviewed for identification of information necessary to track the imbalance, such as linking receipt points to the operational impact areas -- which may also be necessary for trading. Definitions may be needed for netting and trading. Netting may be an activity across a customer's contracts, and authorization may not be required. Trading is between two or more customers, and authorization may be required. The discussion so far pertains to trading and the group will analyze the results to determine if they apply to netting after addressing the issues for trading.

The authorization by or for specific date ranges would define the calendar time period for which the authorization is effective. It is the dates for which the information can be posted, similar to the date range for posting capacity offers. It should be applicable to all types of authorization except where no authorization is required. Overwriting and changing the specified date ranges (item no. 8) should be as a replacement not a modification, to reduce the complexity and errors. The replacement of the date range would be at whatever level the original authorization was granted. The replacement would be for prospective dates -- it is not retroactive. It is unlikely that authorizations would change very often. De-authorization or an indicator to not authorize posting for trading was added as item no. 11. Item no. 11 should be applicable to all levels. Replacement should work in the same manner for non-date issues, such as adding a contract or subtracting a contract from the authorization list. As a premise, different types of authorizations should be captured in one document. The de-authorize function would effectively de-authorize all authorizations contained in the entire document.

The daily/monthly authorization for imbalances (item no. 5) has been addressed through the specific date range (item no. 4). Timing issues do not apply to authorization; they are defined as the time by which the authorization should be received. It was recommended that the authorization deadline be defined as by 9:00 p.m. central clock time, two calendar days before the posting would occur, (eg. for postings effective on Wednesday, authorizations must be submitted by 9:00 p.m. Monday). After debate, there was no recommendation forthcoming. All authorization items should be revisited after the posting issues are addressed to ensure cohesiveness.

## **Discussion -- Posting:**

For discussion on posting by specific area or zone, legal entity, rate schedule, specified Contracts, operational impact areas and imbalance type, please refer to the discussion in the authorization section of the minutes. The remaining items were not discussed due to time restrictions, and will be placed on the agenda for the next meeting.



# Gas Industry Standards Board

1100 LOUISIANA, SUITE 4925, HOUSTON, TEXAS, 77002  
PHONE - (713) 757-4175, FAX - (713) 757-2491, email gisb@aol.com  
HOME PAGE www.gisb.org

## Results of Discussion<sup>1</sup>:

<u>Authorization BY (for posting for trading):</u>	<u>RESOLVED</u>
1. Authorization by specific area or zone	NO
1A. Legal entity	YES
3. Authorization by specified rate schedule	YES
2. Authorization by specified contracts	YES
<i>(For item nos. 1A, 2, and 3 operational impact areas can be specified within each of those items)</i>	
9. Imbalance Type	YES
7. Operational Impact Areas ("Op Areas")	YES
10. No Authorization Required	YES
4. Authorization by/for specified date ranges	YES
5. Daily/monthly issues	NO
6. Timing Issues	NO
8. Overwrite/Change authorization issues - replacement	YES
11. Don't Authorize -- De-authorize	YES
<u>Posting BY (for trading):</u>	
1. Posting by specific area or zone	NO
1A. Legal Entity	YES
1B. Rate Schedule	YES
1C. Specified contracts	YES
<i>(For item nos. 1A, 1B, and 1C operational impact areas can be specified within each of those items)</i>	
7. Operational Impact Areas	YES
11. Imbalance Type	YES
2. Daily/monthly issues	
3. Timing issues	
4. Nomination process issues (per proposed standard No. 1.3.X)	
5. Administration	
6. Concurrency of trades	
8. Total/changes only posting	
9. Zero Imbalance posting question	
10. OBA Imbalance posting question	
12. Percentage or Specific Quantity	

<sup>1</sup> The numbering was preserved from the original work paper to note which items were addressed and not addressed during the meeting and which items were added if compared to the original work paper.



# Gas Industry Standards Board

1100 LOUISIANA, SUITE 4925, HOUSTON, TEXAS, 77002  
PHONE - (713) 757-4175, FAX - (713) 757-2491, email gisb@aol.com  
HOME PAGE www.gisb.org

## Results Charted -- Authorization

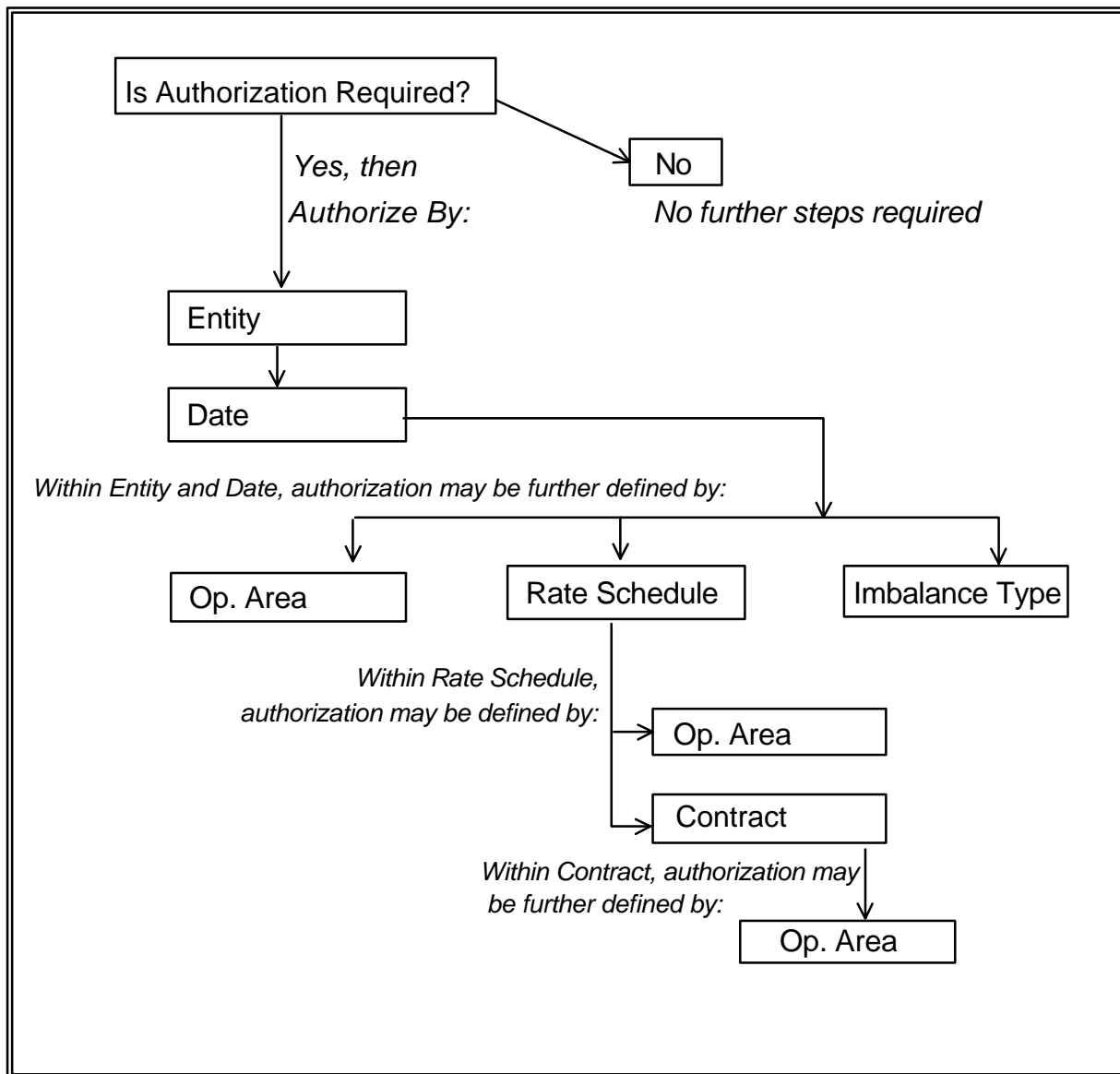

#### IV. Next Meeting of the Imbalance Subcommittee

Outstanding questions will be drafted for review at the next meeting by Dale Davis and Jim Buccigross. Attendees should be prepared with answers and provide them for posting if possible. The questions will be posted on June 2. Written responses should be forwarded to the GISB office on June 5 for posting. Teleconference call for the next meeting of the Imbalance Subcommittee is June 8, 9:00 a.m. to noon central. Following meetings are scheduled for June 17 and June 29, both from 9:00 a.m. to noon central. The agenda for June 8 is to continue discussion on authorization and posting and to review the outstanding questions and responses.



# Gas Industry Standards Board

1100 LOUISIANA, SUITE 4925, HOUSTON, TEXAS, 77002  
PHONE - (713) 757-4175, FAX - (713) 757-2491, email gisb@aol.com  
HOME PAGE www.gisb.org

---

V. Adjourn

Meeting adjourned at 4:00 p.m.

VI. Attendance

Segment		GISB Members	
SERVICES:	Jim Buccigross	National Registry	✓
	Donna Scott	Enron Administrative Corp.	✓
	Greg Lander	TransCapacity	✓
PIPELINES	Sherry Wake	ANR	✓
	Cindy Reppke	ANR	✓
	Flo Comini	ANR	✓
	Mary Sue McNeal	El Paso Energy	✓
	Laura Moseley	FGT	✓
	Julie Unruh	Koch Gateway	✓
	Sandra Barnett	Mobile Bay	✓
	Karen Boren	NGPL	✓
	Lynn Blair	Northern Natural	✓
	Brent Phelps	Panhandle Eastern	✓
	Lynn Ledlow	Sonat	✓
Rita Jones	Texas Gas	✓	
Dale Davis	Williams Gas Pipelines	✓	